

# CHAPTER SIX

## BASIC SAILMAKING

0601	Types of Material	
0602	Make-up of Canvas	
0603	Sailmakers Tools	
0604	Sewing Skill	Hand Sewing Flat Sewing Round Sewing Tabling
0605	Repairing Canvas	Patching Darning
0606	Grommets	

### 0601 TYPES OF MATERIAL

a) **Canvas** – is a cloth woven from yarns, which can be made from fibres of flax or hemp. It can be treated to provide flame-resistance, water-repellent and rot-resistance capabilities. The strength of any type of canvas is obtained through the different types of weave in the manufacturing process. Canvas supplied by the Royal Navy is provided in different weights, No 1 being the thickest and heaviest and No 7 the thinnest and strongest.

b) **Cotton** - there are several types available ranging from heavy to light material.

c) **Synthetic Fabrics** - manufactured from materials such as Nylon and Polyester. The yarns and cloth are heat set at manufacture to prevent stretching.

d) **Coated Fabrics** - Nylon, Terylene and natural fabrics can be coated with various substances to produce fabrics which combine the advantages, such as lightness, strength or cheapness, of the base fabric with additional advantages conferred by the coating. The principal coatings in use are PVC (Polyvinylchloride), Neoprene, Polyurethane, other synthetic rubbers and natural rubber, each of which has particular advantages for the user of the finished fabric.

## 0602 MAKE-UP OF CANVAS

The threads that run across the breadth of the canvas are called the weft, and those which run throughout its length and are rove alternately over and under the threads of the weft are called the warp. As the weft is continuous and unbroken the canvas does not fray at the selvages (sides of each strip), but it will fray at the ends of each strip and wherever it may be cut; such an edge is known as a raw edge and is never permitted in sailmaking, either when sewing canvas or in the completed job.

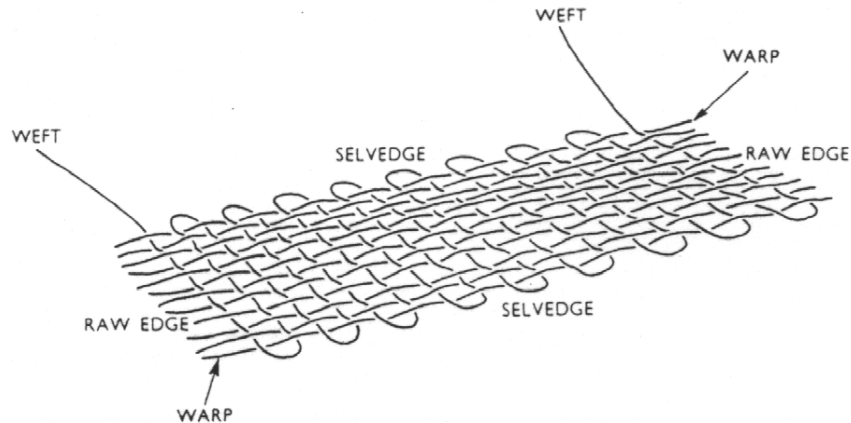

## 0603 SAILMAKERS TOOLS

- a) **Hand Sewing Needles** - these are known by their numbers - No 17 being the smallest. The most common sizes used as sailmaker's needles are No 17 and a No 14.
- b) **Hand Sewing Palm** - the sailmaker's palm replaces the thimble used in domestic sewing and is used to push the needle through the material. Palms are of two types, the seaming palm which is used for ordinary sewing and the roping palm used with the heavier needles and twine to sew rope and canvas.
- c) **Sail Hook** - is a metal hook secured to a lanyard and used to hold one end of the canvas while sewing. It acts as a 'third hand' for the sailmaker.
- d) **Rubber** - this is a metal tool with a wooden handle, used to flatten out the stitching of a round seam after sewing and also to rub down a turned-in edge before sewing.
- e) **Sailmaker's knife** - an open bladed knife used for cutting material.
- f) **Pricker** - a round metal spike with a wooden handle, used for making small holes in canvas.
- g) **Splicing Fid** - made of a hard wood and used for splicing rope and opening out cringles.
- h) **Punches and Dies** - supplied in various sizes they are used to fasten metal grommets to canvas.
- i) **Grommets** - consist of a metal eyelet and a spur-toothed washer which are used to put a solid eye into canvas or other material.

Examples of Tools

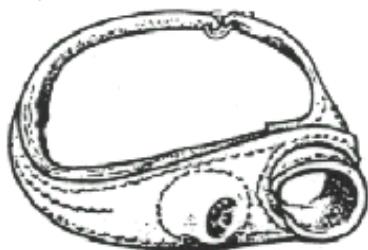

SEAMING PALM

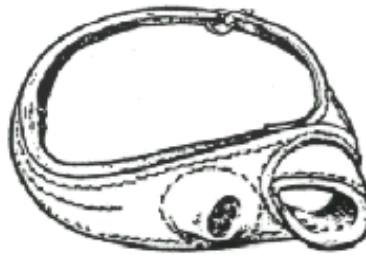

ROPING PALM

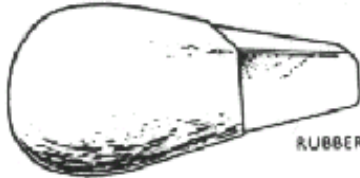

RUBBER

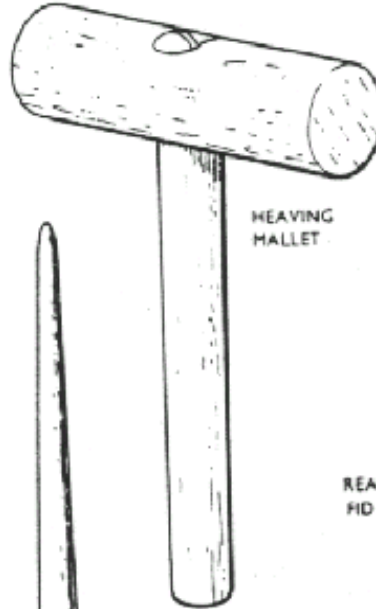

HEAVING MALLET



SHOEMAKER'S KNIFE



SAIL HOOK



PRICKER



CANVAS PIERCER



No. 14 NEEDLE



No. 12 NEEDLE



SPLICING FID



REAMING FID

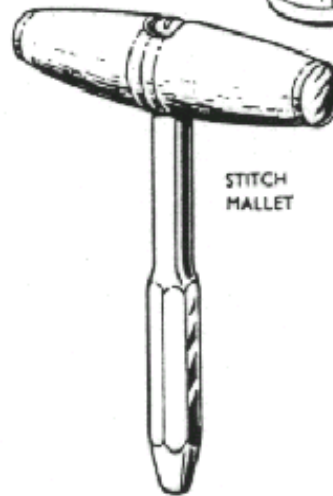

STITCH MALLET

## 0604 SEWING SKILLS

### 0604.1 Hand Sewing

Before starting to sew, the palm should be adjusted so that it fits the hand comfortably. A palm which is too tight or stiff, is likely to cause cramp in the hand and this can be prevented by soaking the palm in hot water to make it pliable.

When making stitches, the point of the needle should be held between the forefinger and the thumb, the middle finger being used to guide the eye of the needle to the pellet of the palm each time the needle is pushed through the material.

Stitches should be hand taut (an approximate pull of 7 lb) and each stitch must be as taut as the others. When sewing with twine it should be well rubbed with beeswax which helps to preserve the twine, prevent tangles while sewing and lubricate the twine so that it will pass through the material more easily.

When turning in the edge of canvas before sewing a seam, it is necessary to rub down the new edge with a rubber or other suitable tool (the back of a knife blade will do), this keeps the fold in position while sewing. The process is also carried out after the seam has been sewn to make the seam lie flat.

***Holding the Needle***

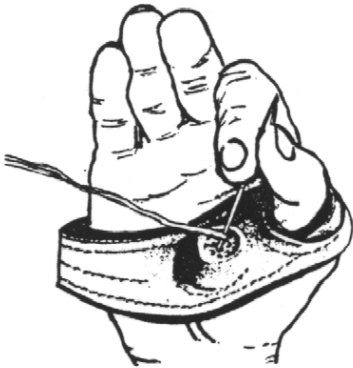

***Inserting the Needle***

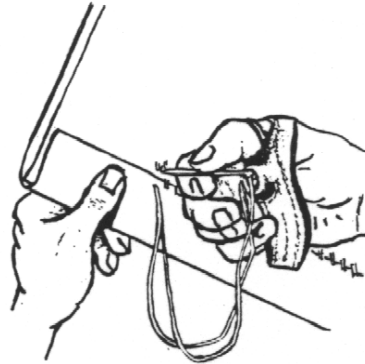

***Pushing the Needle through***

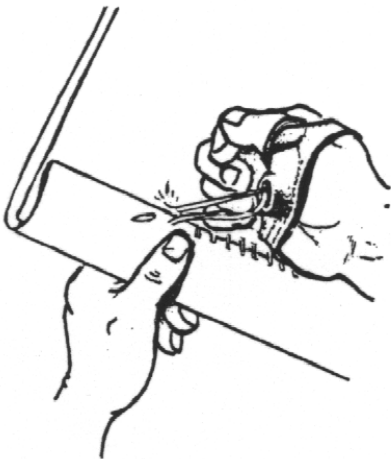

***Completing a Stitch***

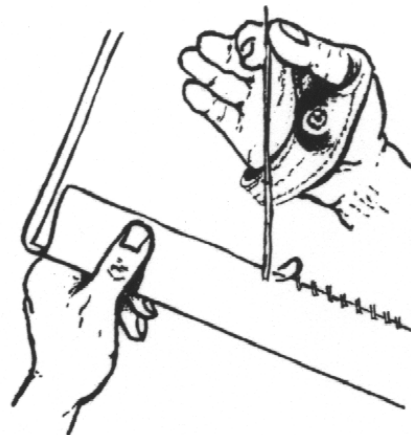

## 0604.2 Flat Sewing

This is a simple method of joining two pieces of fabric when strength is not particularly required. Place the selvedge of one piece of canvas onto the seam line of the other, hook both pieces of canvas on to a sailmaker's hook, keep the cloths flat on the knee and sew away from the hook using approximately 3 stitches to 25mm (1 inch). The needle should pass through the single cloth close to the selvedge and seam line and up through the two cloths close to the other side of the selvedge. The job should then be reversed and the other selvedge sewn to the other seam line.

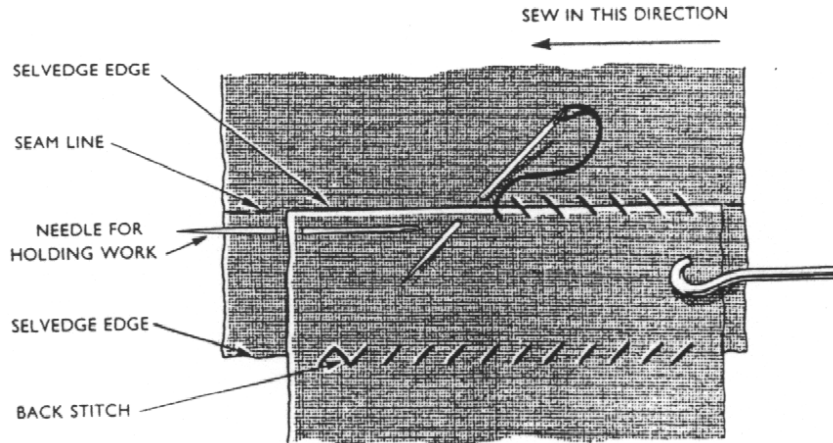

## 0604.3 Round Sewing

Because the stitches in round sewing pass through more parts of the fabric this gives a stronger joint than flat sewing.

- a) **Single Last** - to sew, turn both cloths at the edge about 13mm and rub down; place the two cloths together with the turned-in edges outwards, fasten both cloths to the sailmaker's hook, start sewing at the end furthest from the hook and work towards it. The stitches should be made by passing the needle through all four parts of the canvas about 3mm from the edge and back over the top making three or four stitches to every 25mm (1 inch). When finished, open out the two cloths and rub down the seam to flatten it out. This seam can also be sewn with the turned-in edges of the cloths towards each other.

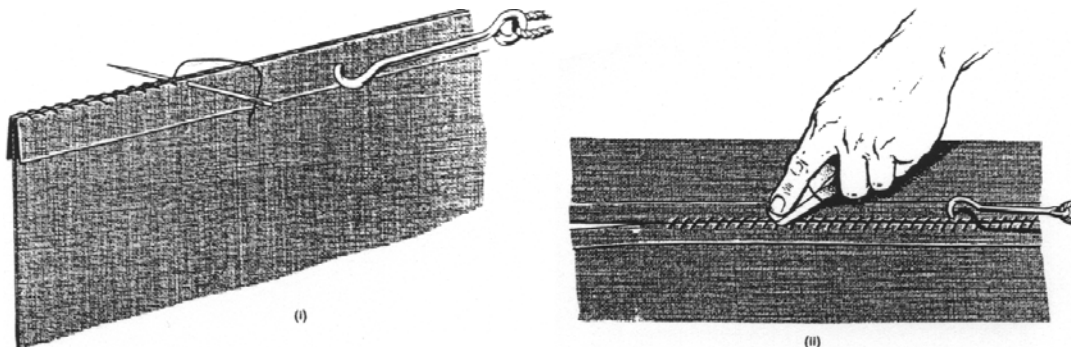

- b) **Single Round Seam** -to sew a round seam, turn in one cloth at the seam line, rub down and place the rubbed-down edge on the selvedge of the other cloth with the turned-in part towards it. Fasten both cloths to the sail hook with the unfolded cloth

towards you and sew towards the hook making approximately four stitches to 25mm (1 inch), the needle passing through all three parts of the material and back over the top. After sewing open out the cloths and rub down the seam.

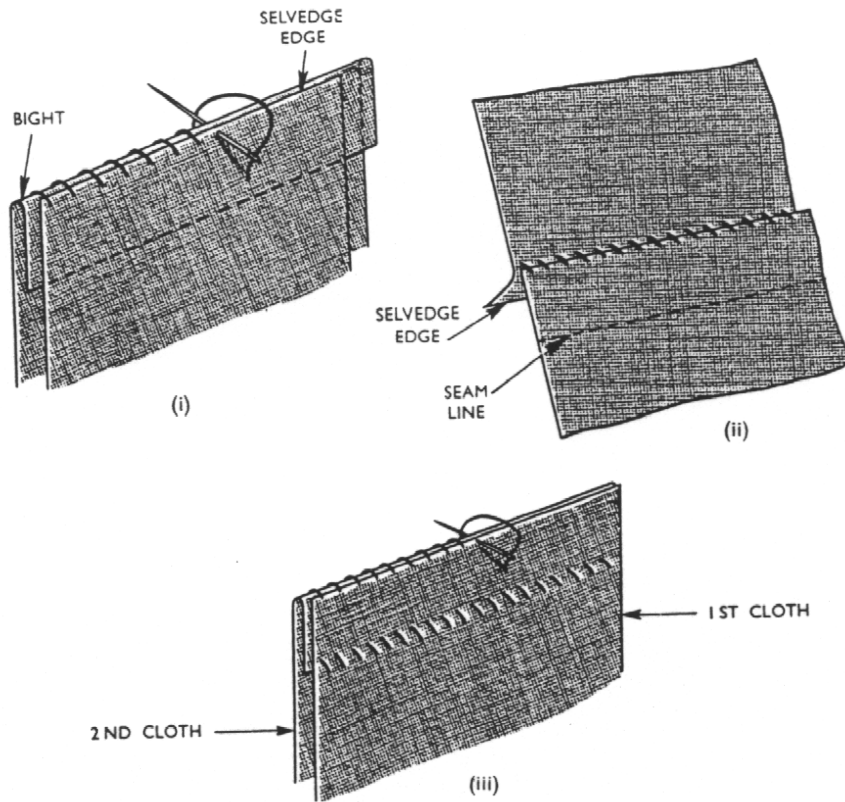

#### 0604.4 **Tabling**

Tabling is the name for the double thickness of material at the edge of a job similar to the hem in a garment. Besides giving a neat finish to the article, it prevents the edge, and particularly a raw edge, from fraying, and gives added strength where it is necessary to fit grommets, cringles, etc. Tabling is made by turning in the edge of the material, and then turning in the edge again underneath its own part and sewing the folded edge to the material as in the diagram below, then sewn as a flat seam.

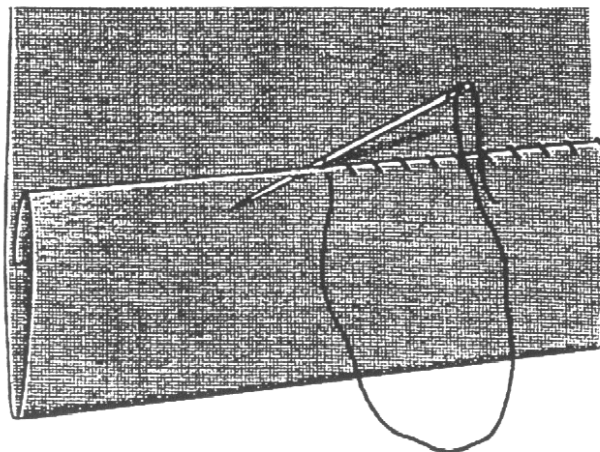

## 0605 REPAIRING CANVAS

Damage to canvas is likely to be in the form of a tear or a hole. If a hole is very large, extending over half the width of a cloth, it will be advisable to replace the whole width of the cloth.

### 0605.1 Patching

A piece of canvas of the same grade as the damaged canvas is cut to a size which, when laid over the hole, extends 50 to 75 mm beyond the limits of the hole in all directions. Lay the patch over the hole so that the warp threads run in the same direction as those of the canvas being repaired, then put a small stitch in each corner to hold the patch in position. Turn in 13mm on all sides of the patch, mitring the corners, and sew the patch on to the canvas with a flat seam, taking care to secure the corners properly. If one edge of the patch is selvedge there is no need to turn it in.

The work is then turned over and the edges of the hole are trimmed with a knife so as to leave a strip 40mm wide (50mm in No 2 canvas) all round inside the line of stitching. Cut the corners so that 13mm of the strip can be turned in and sewn down with a flat seam.

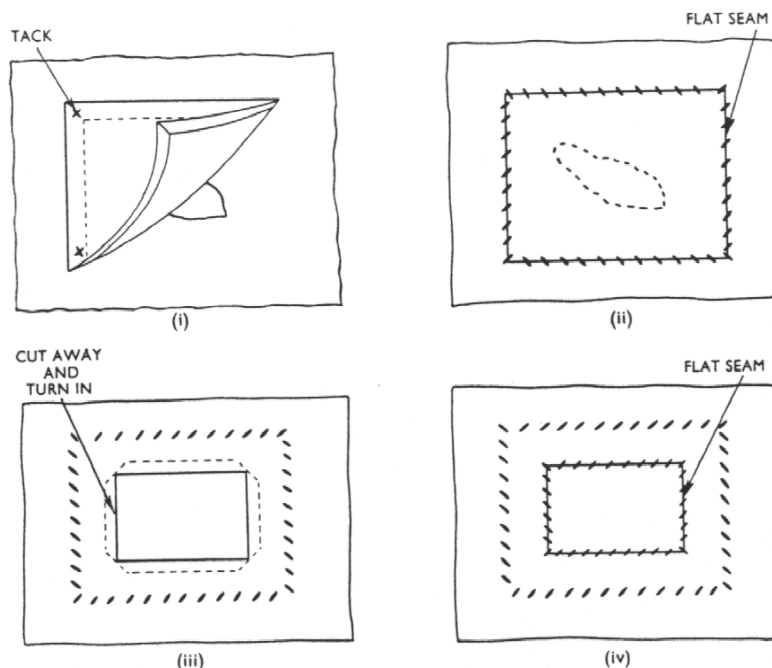

### 0605.2 Darning

This is used for repairing small tears. The canvas is held so that the tear points directly at the sailmaker. The first stitch is made by bringing the needle up through the canvas, just to the left of the end of the tear, then down through the canvas on the right side and up through the tear, and then through the bight of the twine so formed. Subsequent stitches are made by passing the needle down through the tear, up through the canvas on the left side, down through the canvas on the right side, leaving a small bight in the twine, then up through the tear and the bight. Each stitch is drawn taut as it is finished, and the darn consists of a series of locked stitches sewn closely together.

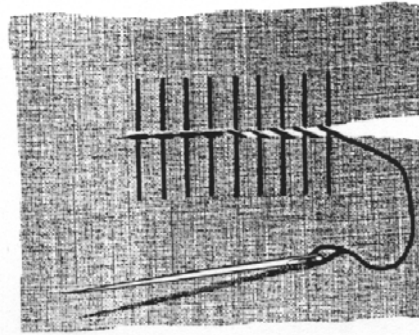

## 0606 GROMMETS

If a hole were cut into material and used without strengthening, the material would quickly tear; so it is strengthened with a grommet of metal or rope.

a) **Metal Grommets** - are normally made of brass in two halves. A hole is first made in the material with a piercer or wad punch. The appropriate die, the spur-toothed grommet washer, the hole in the material and the grommet eyelet are aligned with a metal or wooden spike (not a fid). The punch is then hammered down so that the spur teeth grip the cloth and the shaft of the eyelet splays out and grips the material between the two halves.

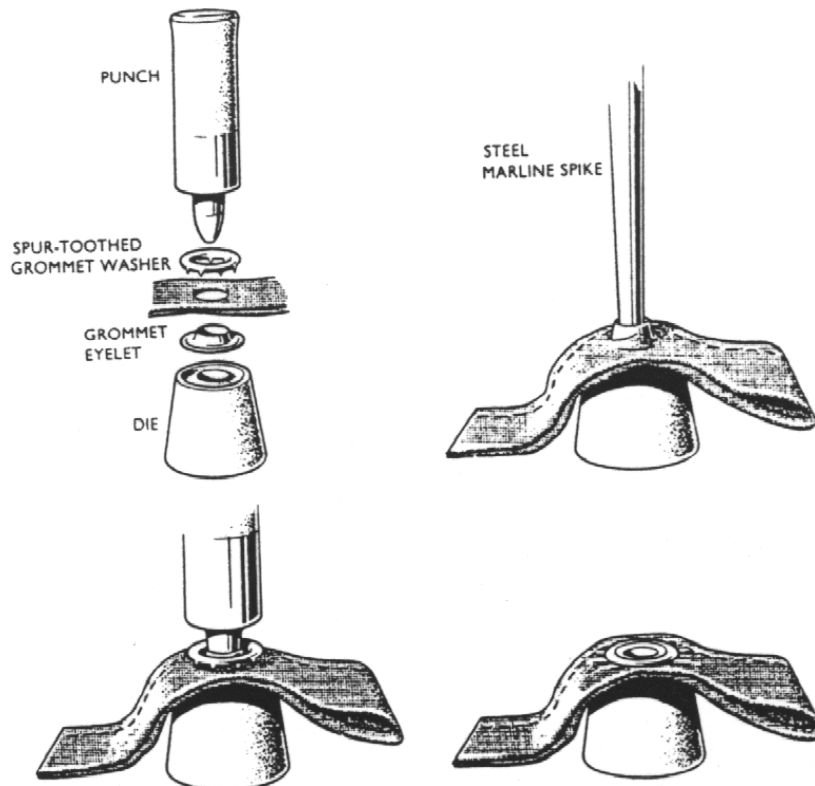

b) **Rope Grommets** - are made from a single strand of rope. To 'work an eye', place the grommet on the material, mark inside the circumference and cut out this circle. Sew the grommet to the material on the same side as any roping, passing the needle down through the material outside the grommet and up through the hole until the grommet is well covered by the twine.



# CHAPTER SEVEN

## DECORATIVE ROPEWORK

- 0701 Wall and Crown knot
- 0702 Crown and Wall Knot
- 0703 Turks Head
- 0704 Man-rope Knot
- 0705 Cockscombing
- 0706 Chain Shortening
- 0707 Sennits
- 0708 Coachwhipping

### 0701 Wall and Crown Knot

This can be used to prevent a rope such as a rudder lanyard from unreeving, and also to form the foundation for more advanced knots. The whipping is placed at a distance from the end equal to 20 times the diameter of the rope, the wall being formed first and the crown made on top of it.

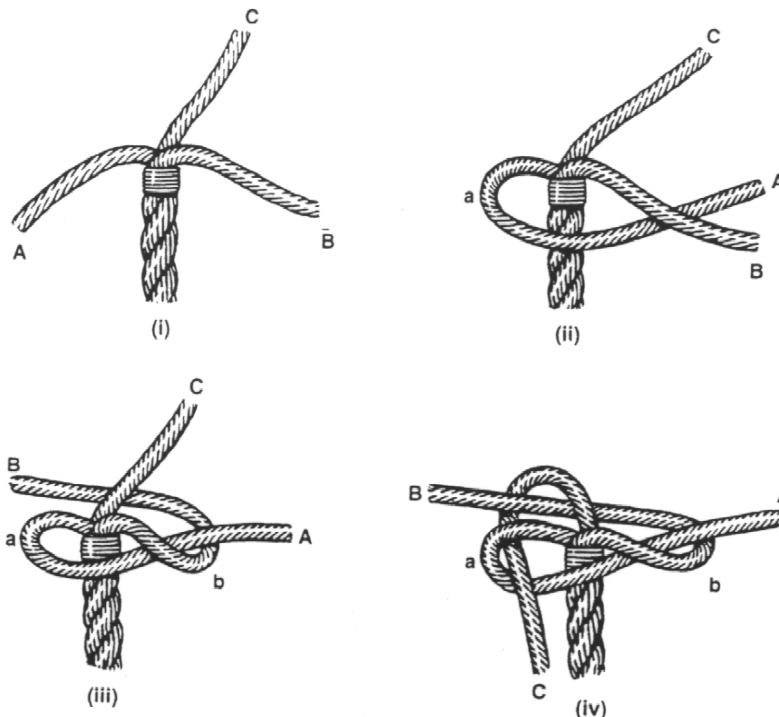

## 0702 Crown and Wall Knot

This differs from the wall and crown in that the crown is made first and the wall formed under it. It is used for finishing off the end of seizings to prevent them from unreeving. The strands are unlaied right down to the turns of the seizings, against which the crown is formed as close as possible. The wall is then made under it and hauled taut, thus jamming the knot in tightly.

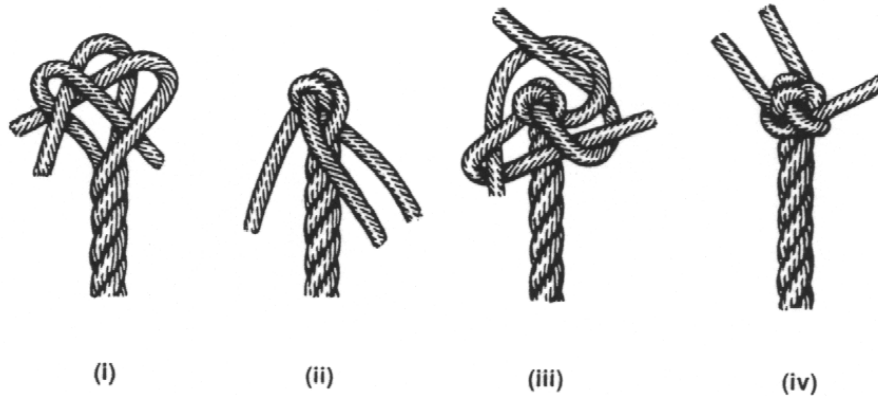

## 0703 Turks Head

The Turk's Head is an ornamental knot supposed to resemble the turban once worn in Turkey, and should consist of three or more parts followed round two or more times. It may be made either as a standing or a running knot, according to whether it is to be fixed to an end or a bight, or is to be formed round another part of rope or a post or stanchion for example.

- a) **Standing Turk's Head, made at the end of a rope.** This is a manrope knot but the ends are followed round a third or fourth time. To make the Manrope knot, whip the rope at a distance of not less than 25 times the diameter of the rope, unlay the strands to the whipping, and whip the ends. Make a wall and crown knot, keeping the knot fairly loose. Then take each strand and follow its own part until three parts have been made. Haul all parts taut and cut off the ends where they protrude from the base of the knot.
- b) **Running Turk's Head, made at the end of a rope or round its own bight,** (as in a running lanyard). This is similar to a standing turk's head except that the wall and crown with which it is begun are made round the bight of the rope. The strands are then followed round two or more times, thereby forming a knot, which will slide up and down the bight.

### ***Standing Turk's Head***



### ***Running Turk's Head***



### **0704 Manrope Knot**

This is used as a decorative knot on the end of a rope. Make a fairly loose Wall and Crown knot, then starting with strand A follow it round its own part, so doubling-up strand A. Work the other strands the same way then haul all parts taut. Cut off the ends where they protrude from the base of the knot.

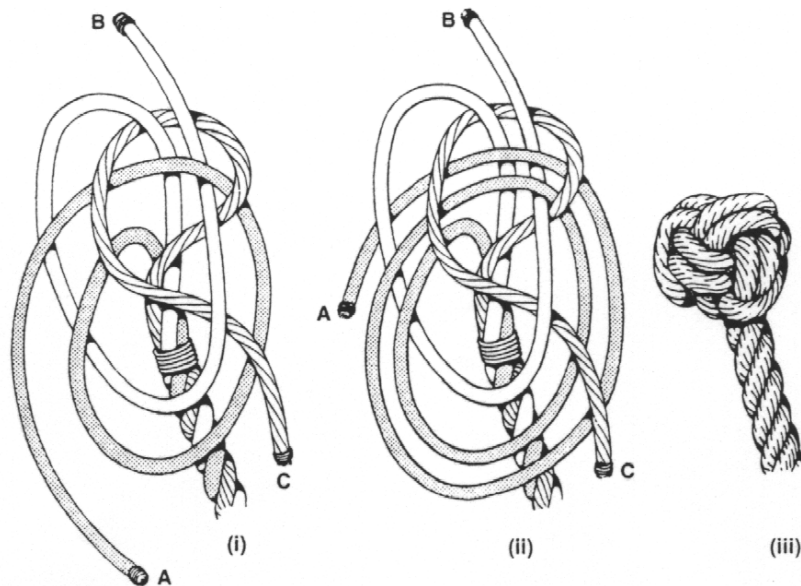

### **0705 Cockscombing**

This is generally used to cover a ring or an eye but can be used as a neat finish on bag handles or on lengths of rope. Seize the ends of three lengths of cord or line to the fitting, allowing two lengths to hang on the right and one on the left (i). Take the furthest right-hand part and make a half hitch round the fitting, with the end coming out to the left and top of the fitting (ii). Then take the part which has not been used and make a half hitch round the fitting to the left, with the end coming out to the left and on top of the fitting (iii). Continue this half hitching with each part in succession, alternately to one side and to the other and always using the farthest-back part, until the fitting is covered (iv). Finish off each part either by making a crown and wall knot, by passing the strands through the laid up length and trimming off, or by whipping all the ends together and trimming the ends. The whipping may then be covered with a Turks Head.

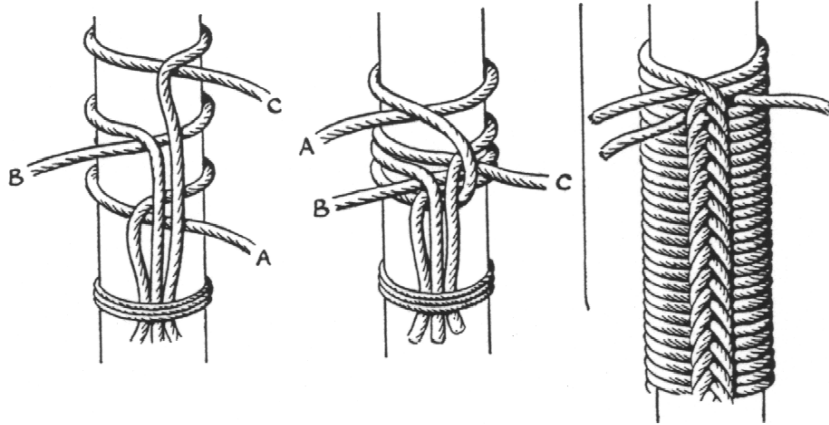

### 0706 Chain Shortening

This is a series of hitches used for shortening the end of a rope; it looks very neat, and is useful when only a short length of rope can be handled at a time. It is made as follows:

- a) Form a loop in the rope.
- b) Pull the bight up through the loop, to form another loop.
- c) Pull the bight through again, and repeat until the shortening is sufficient.
- d) Secure the last loop, either with a toggle or by passing the end of the rope through it.

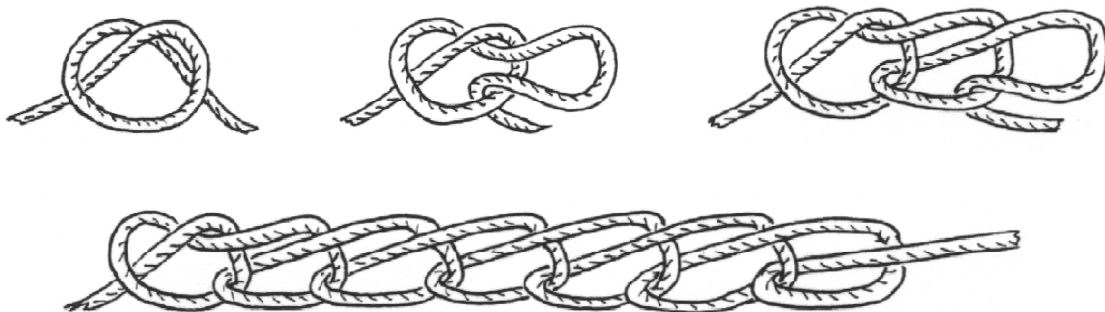

### 0707 Sennits

There are a number of different types of Sennit, the most popular being a Portuguese Sennit, which can be made flat, spiral or a combination of both. (This type of decorative ropework is very popular for covering belts and making light pull cords).

There are only two working strands, which sit either side of a central heart, which could be a number of strands, usually two or three, or a single core (rope or a belt).

To start the sennit the left hand strand is passed under the heart and over the right hand strand, a bight being retained on the left (i). The right hand strand is brought across, over the heart, down through the bight (ii), and both ends are drawn tight (iii).

Having completed the first tuck of each working strand, if a spiral is required repeat the process commencing with the looping of the left hand strand as at the start. After a number of tucks a spiral will clearly be formed.

The spiral can be reversed by commencing with the right hand strand being passed under the heart and over the left hand strand, a bight being retained on the right. The left hand strand is brought across, over the heart, down through the bight and both ends drawn tight.

To ensure a Flat Sennit, complete the first series of tucks and draw tight. Having commenced with the left hand strand making the loop, now make a loop with the right hand strand, pass the left hand strand over the heart, down through the bight and draw tight. Continue to alternate the tucks left and right.

The sennit may be completed by whipping or heat sealing the ends or by tucking back on itself and trimming the ends.

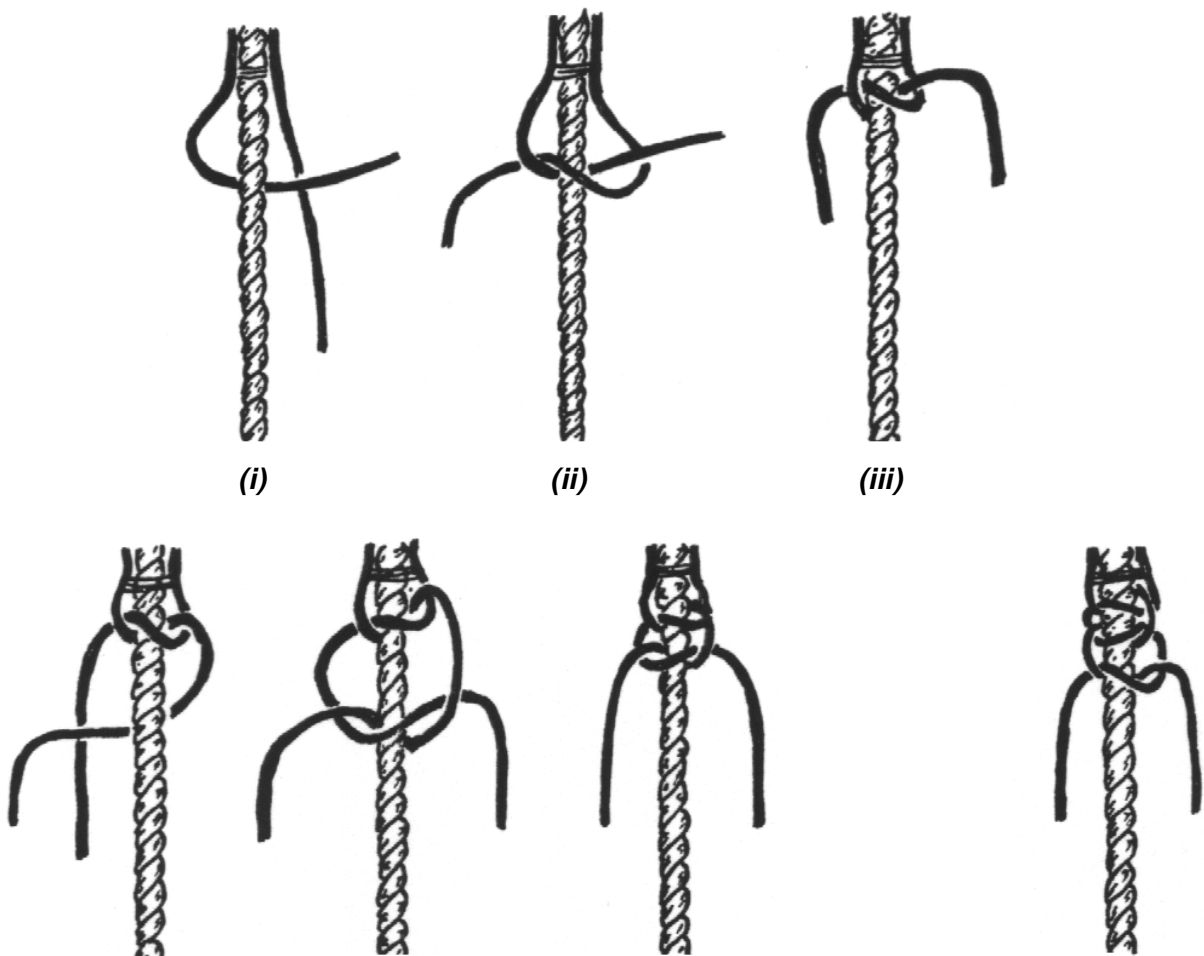

**0708 Coachwhipping**

Coachwhipping is a covering based on the square sennit. The most common method is to use eight strands, formed by attaching four strands at their mid points to the fitting to be covered, by a means of a twine seizing. This will provide eight strands, four above and four below the seizing.

Take the four above down and to the right of the seizing, whilst the four below are taken to the left.

Then take the strand furthest to the right round the back of the fitting, returning to the front between the second and third strands from the left, leaving the worked strand as the new fourth strand from the right at the finish.

Then take the strand furthest to the left round the back of the fitting, returning to the front between the second and third strands from the right, leaving the worked strand as the new fourth strand from the left at the finish.

The previous two stages are then repeated until the desired length of covering is achieved, finishing with another twine seizing around all eight strands and the fitting. This gives a finished appearance of four lengthwise rows of ***herringboning*** along the covering.

Both ends would often be covered with Turk's Heads to hide the seizings and cut ends.

***First tuck***

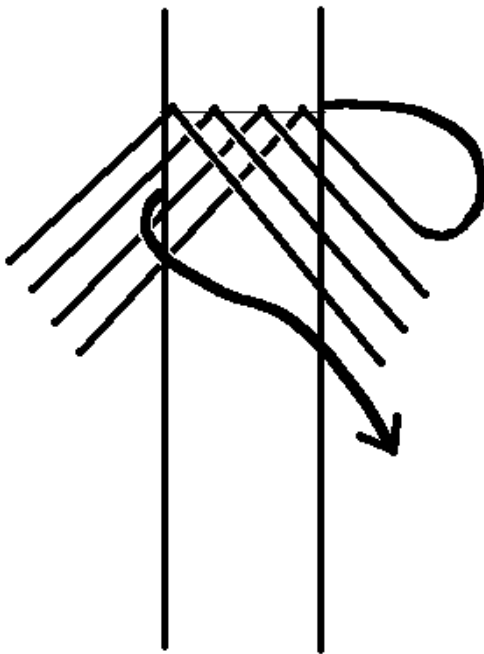

***Finished appearance***



# CHAPTER EIGHT

## BASIC BOATWORK

**0801 Ceremonial Boathook Drill**

**0802 Securing and Anchoring a Boat**

### 801 CEREMONIAL BOATHOOK DRILL

Ceremonial Boathook Drill is carried out in boats when Senior Officers, in Uniform, are being conveyed to and from Official visits or functions. It may be used at events such as Regattas where Dignitaries and Senior Officers are being conveyed.

The drill is normally carried out by a Bowman and a Stern sheetsman, on a Ceremonial Barge with both crew members standing firmly on a bow and stern platform. This drill may also be carried out by a single bowman.

When coming alongside a jetty or ship, the Ceremonial Boathook Drill is carried out when the boat is approximately 50 metres away. This allows sufficient time to complete the drill without rushing, before making use of the boathook to hook on.

On leaving from alongside, the drill is carried out immediately when the boat is at least 2 metres clear of it's alongside position.

The following drill if carried out correctly will allow for boat's crew standing in a boat instead of on an upper platform, and will avoid the necessity to swing and turn the boathook thereby avoiding accidents. It is important that the Coxswain designate which side he will be coming alongside to in plenty of time for the crew to prepare.

#### **STAGE 1**

The bowman should be standing at ease with the boathook stave firmly held straight up and down, the hook facing downwards. The top hand will be either the left hand (when coming alongside Starboard Side to) or the right hand (when coming alongside Port side to). The hand is turned palm outwards so that the boathook is correctly held when raised aloft. The other hand grasps the boathook stave in the normal manner.

In the event that a Bowman and a Stern sheetsman are detailed for the Ceremonial Boathook Drill, both will be standing At Ease and in the same positions with boathooks.



The drill is carried out dwelling a pause of *two marching paces* between each movement.

**STAGE 2**

The bowman taking the lead will raise and lower the boathook twice striking the deck on each lowering of the boathook. This will signal to the stern sheetsman to prepare for the drill. A pause of two marching paces are then dwelt before going to Stage 3.

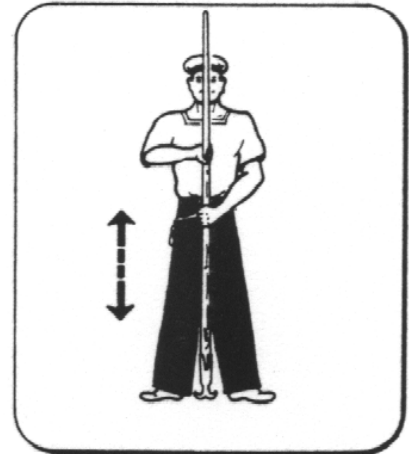

**STAGE 3**

The boathook is then raised smartly, horizontally and at full aims length above the head. (The hook will face the direction of the side going along to).

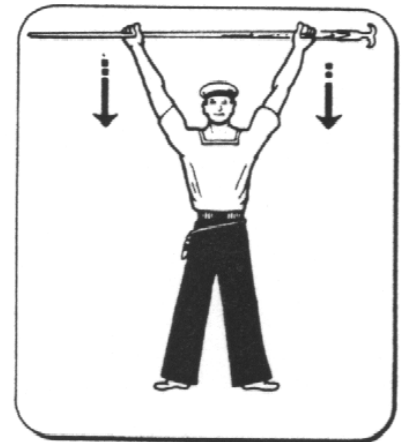

**STAGE 4**

Having dwelt a pause of two marching paces the boathook is lowered to shoulder height.

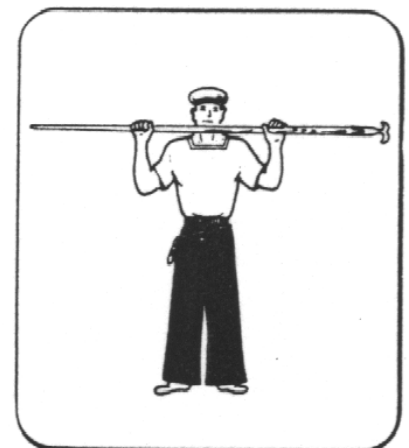



## **STAGE 5**

After a further two marching paces the boathook is lowered to the full extent of the arms.

The boathook is then prepared for use on the respective side.

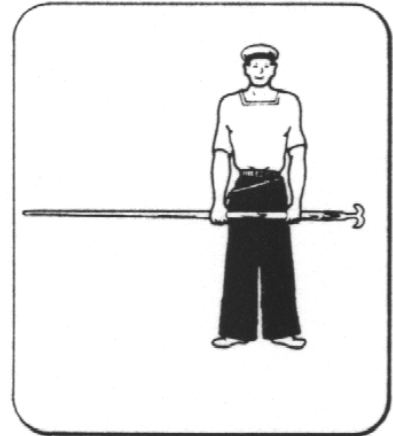

Having left along side the crew will fall in as at Stage 1. When ordered by the Coxswain to 'Fall Out' the Drill is carried out again to Stage 5 then the boathook(s) are stowed away.

## **0802 SECURING AND ANCHORING A BOAT**

### **0802.1 Securing Alongside**

Boats are normally secured alongside by use of **Bow and Stern lines** known as **Head and Stern ropes**. Where possible the ropes are passed from the boat, out through fairleads, around bollards or through rings in either the jetty or other boat that you are alongside. Both ropes are then returned into the boat, via fairleads, and secured to rings, cleats or round the forward thwart.

It may not be possible to pass your bow and stern lines back into the boat, so they should be secured to the jetty fixture by a round turn and two half hitches.

Care should be taken to allow for the rise and fall of the tide (Tidal Range) in tidal waters, so that sufficient slack is left in both ropes in order that the boat is not left hanging nor sunk, by them.

Fenders are positioned along the boats side to prevent damage between the boat and the jetty/other boat. Fenders are normally brought inboard when a boat is underway and so it must be remembered to order "Out Fenders" in good time before coming alongside. They must be placed where the boat is most likely to make contact with another boat or jetty, this includes not only their present position laterally but their height as well. Fenders are normally secured to inboard cleats or the risings by lanyards. A lanyard at each end of a fender thus securing it horizontally in two places offers more control, especially important in tidal waters where fenders will tend to ride up and roll with the movement of the tide.

### **0802.2 Securing for a long stay or rough weather**

In rough weather a boat secured only by Head and Stern lines will tend to move backwards and forwards along a jetty, swinging on her lines. In order to prevent, this additional lines called **Springs** may be used. Additional fenders may also be required.

A **Fore Spring** is used to stop the boat moving forward. It is attached in the fore part of the boat then runs aft to the jetty.

A **Back Spring (After Spring)** is used to stop the boat moving backwards. It is attached in the after part of the boat and runs forward to the jetty.

An additional option may be to include two lines known as **Breast Lines, Fore and After**.

These lines help to hold the boat into the jetty.

**Example of Securing Lines**

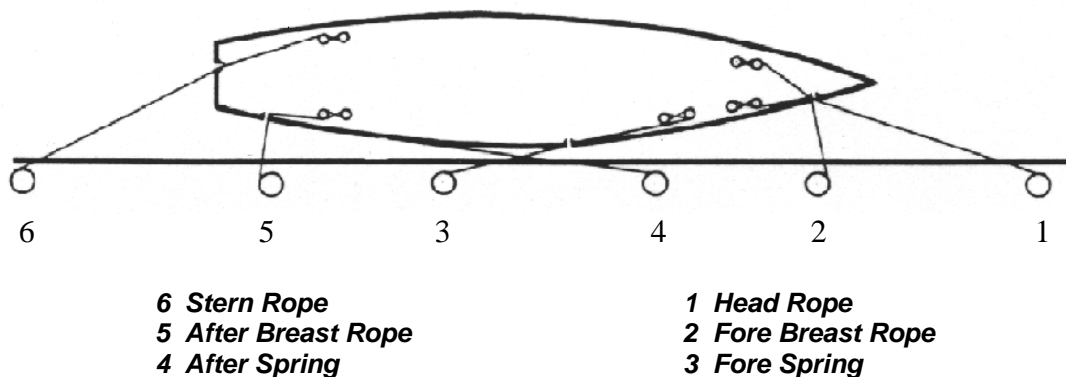

### 0802.3 Anchoring

The type of anchor used in small boats will in most cases be either an Admiralty Plan (Fishermans), Plough or CQR or Danforth type as these are the most popular types of small boats anchor.

When anchoring the most important thing to remember is to ensure that the inboard end of the anchor cable (warp) is secured to a strong point in the boat. The outboard end of the cable should be securely fastened (bent) to the anchor ring; by shackle if using chain cable or by a Fishermans Bend for a rope warp. If using an Admiralty Pattern anchor ensure that it is correctly made up, stock in position, forelock in place and moused.

**Before anchoring** you will need to know:

- Direction of the current.
- Depth of the water.
- Nature of the Seabed.
- Direction of the wind.

To work out the total amount of cable or warp required to anchor a boat a basic calculation is used:

- Man-made fibre cordage - 6 times the depth of water at high tide.
- Natural fibre cordage - 5 times the depth of water at high tide.
- Cordage and chain - 4 times the depth of water at high tide
- All Chain - 3 times the depth of water at high tide.

It is advisable when using warps a & b to trip the anchor before using it. To do this, take the cordage of the warp to the crown of the anchor and secure it by tying a clove hitch and racking seizing the end. (The trip can be made by using one yarn from a strand of cordage). Lay the cordage alongside the anchor and stretched chain, then allow another 1/2 metre of the cordage. At this mark, join up your trip. When you have joined the trip to the cordage thread it through the end link of the chain and pull it down until the chain is about 4"(10cm) away from the cordage and secure by a series of about 4 half hitches. If the anchor jams under a rock when being hauled in the stop will part (come apart) and allow the anchor to be hauled clear and weighted by it's crown.

Some types of manufactured anchors have an eye or bar already at the crown for securing the warp, if this is the case then it would be easier to have the eye spliced to the end of the warp and shackle it direct. ***Don't forget to mouse the shackle.***

Having been given your anchor berth or selecting it, and having calculated the above, mark off the amount of warp required. If space allows fake enough cable from the anchor to reach the seabed and then fake out the remainder of the cable required for anchoring separately. (In a small boat it may only be possible to coil the warp).

***(Handy hint: A large plastic bucket can be used to hold the anchor warp. A hole should be drilled out in the bottom with the end of the warp passing through it to secure inboard If stowed correctly in the bucket the warp will be free to run out).***

Approach the anchorage either up wind (against) or against the tide, whichever is the stronger. Ensure that you are in the correct position by taking a transit bearing. When in position stop the boat, stream (cast overboard) the cable required to reach the seabed, followed by the anchor. The boat should have gentle sternway on her as the wind or tide push the boat backwards, if not gentle use of the engine (if power boat) is required. Do not go ahead as you may run over or foul (pass the cable around) the anchor. The remainder of the cable should be paid out hand over hand until it is fully paid out to the length required. As the boat drifts back with the current, the bows will pay away from the wind. When the boat has drifted the full length of its warp the bows should pull around to line up with the warp.

This is the first indication that you have got that the anchor has begun to bite. To confirm this take another transit on the beam as this is where the most movement will be noticed if the anchor is dragging.

If when at anchor, the wind or sea gets up (becomes rougher) the boat may start snatching at the anchor. If this is the case there are three options of remedy:

- a) Pay out more warp, the extra weight of the cable laying on the seabed acts as a counter balance.
- b) If this fails a 25kg weight could be secured to the cable by a lizard (use bow or stem line) and allowed to run half way down the cable to the seabed to increase the counter balance effect.
- c) Weigh anchor and head for home.

## Examples of Small Boat Anchors

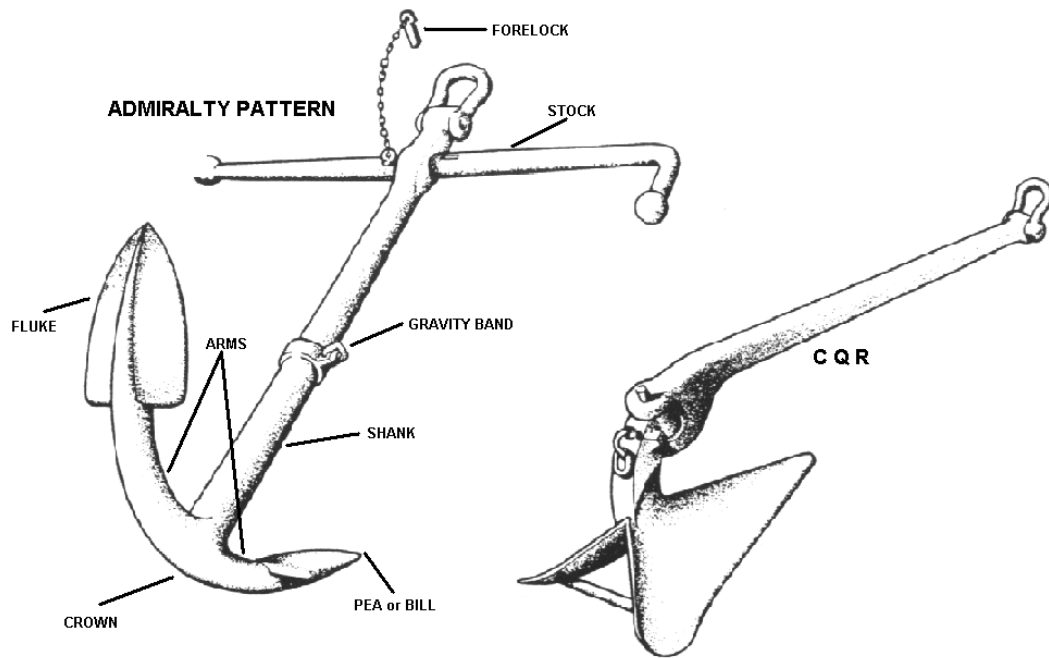

## Chapter 9

# CHARTWORK

### 0901 THE CHART

#### 0901.1 The need for a Chart

A ship can be navigated safely from one port to another by following a selected route on a chart, this is virtually a contour map of the sea bed and its surrounding coastline except, whereas, a land map gives the height of the land contours above sea level, a chart gives the depth of the bottom below sea level. The selected route takes into account the draught of the ship so that there is always enough water under her bottom. Land features and floating marks shown on the chart can be used to fix a vessel's position.

The conventional signs used on a chart are similar to those used on a map and are to be found listed in Chart No 5011 (Symbols and Abbreviations used on Admiralty charts)

#### 0901.2 Latitude

The Latitude of a place is the angular measurement between its parallel of Latitude and the Equator. The angle is measured at the centre of the earth and is expressed in degrees, minutes and seconds (or in degrees, minutes and decimals of a minute) from 0-90 North or South from the Equator. **(ACROSS THE CHART)**

#### 0901.3 Longitude

The Longitude of a place is the angular measurement between its meridian and the meridian of Greenwich. The angle is measured at the centre of the earth and is expressed in degrees, minutes and seconds (or in degrees, minutes and decimals of a minute) from 0-180 East or West of the Greenwich Meridian. **(UP AND DOWN THE CHART)**

#### 0901.4 Distance

The distance scale is the scale of Latitude at the side of the chart, one minute of Latitude being equal to One sea Mile. It is important to remember that this scale alters with the latitude, and that the distance should therefore be measured off that portion of the Latitude scale, which is abreast the position which is to be recorded.

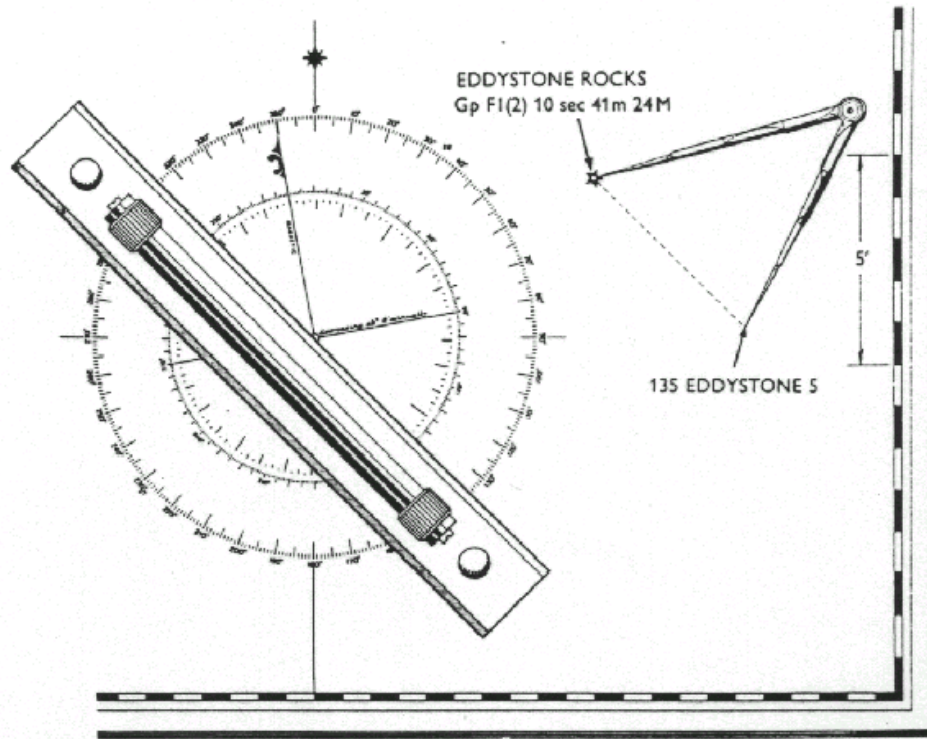

**0901.5 Distance**

The distance of an object from the ship may be expressed in nautical miles (one nautical mile equals 1852 metres), in cables (one cable is one-tenth of a nautical mile) or in metres. (A land mile = 1609 metres).

**0902 COMPASSES**

**0902.1 The Compass Card**

The Magnetic Compass Card is divided into 360 degrees from North (0°) through East (090°), South (180°), West (270°) and so back to North.

The card may be divided into 32 points of 11¼ degrees. The principal points, North, South, East and West are called **Cardinal Points**.

The **Inter-cardinal Points** are North-East, South-East, South-West and North-West.

### Example of a Compass Card

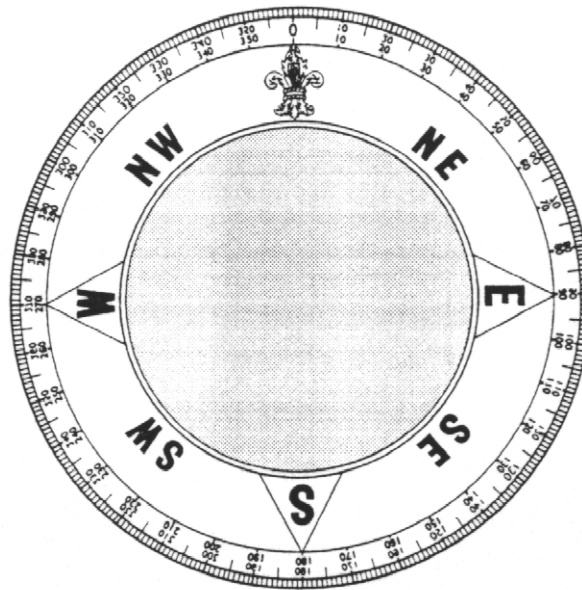

#### 0902.2 Types of Compass

a) **Gyro Compass.** This type of compass obtains its directive force from the rotation of the Earth and seeks True North. The gyroscope is mechanically and electrically dependent upon the ship's power supplies and proper maintenance. It is normally sited as near as possible to the centre of the ship to obtain best performance. By means of electrical transmissions a series of repeaters are used and situated in various parts of the ship for Navigational purposes. There are two main types, a **Bearing Repeater** and a **Steering Repeater**. The bearing repeaters are always mounted in gimbals and gimbals rings in order to maintain the repeater bowl and its compass card in a horizontal position when the ship pitches and rolls. The direction of the ship's head is indicated by a pointer called the 'lubber's line', which is set in the direction of the fore-and-aft line of the ship. The repeater at the primary Navigation position on the compass platform, is mounted in a special stand known as a '**Pelorus**'. Wing repeaters are fitted on brackets in the bridge wings, the bearing repeaters are fitted with a portable Azimuth Circle, which can be rotated round the top of the repeater bowl.

There are two types of steering repeater, one is similar to the bearing repeater, the other more regularly used is a tape repeater. This is an endless tape, mounted on rollers and is viewed through a small window, which allows up to about 15 degrees on either side of the ship's head to be seen.

### **Example of a Gyro Compass Bearing Repeater**

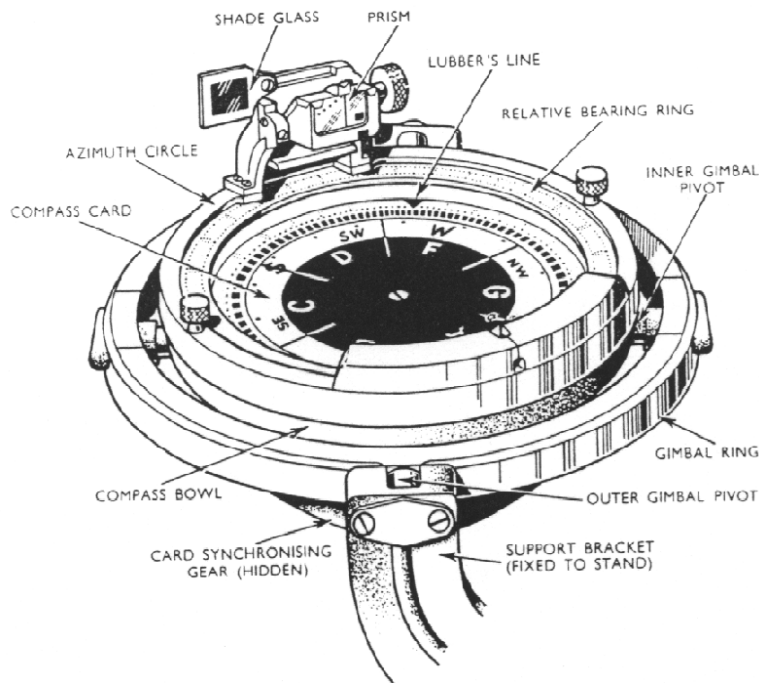

### **Example of a Steering Tape Repeater**

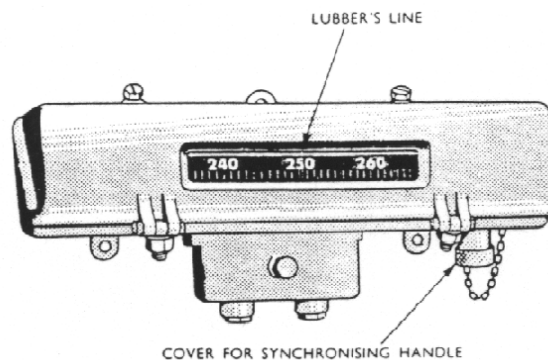

b) **Gyro-magnetic Compass.** This combines the Magnetic North seeking properties of the Magnetic Compass with the stabilising property of a gyroscope.

c) **Magnetic Compass.** This is normally mounted in a binnacle. It is gimballed in order to maintain the compass card in a horizontal position when the ship rolls and pitches. Because the Magnetic compass has its own zone of magnetic influence known as the 'magnetic field', other items of magnetic material in this field will tend to align themselves in the direction of the lines of force. It is important to remember that the functioning of a magnetic compass can be considerably influenced by any magnetic substance close to it. The binnacle therefore is constructed of non-magnetic materials such as wood, brass, and copper as are the fixings. Any magnetic material such as steel and iron, or wires and cables carrying electrical current are kept as far away from the compass as possible. The compass needle is a magnet seeking Magnetic



North. Its accuracy is dependant upon the magnetic properties surrounding it. These properties cause deviation (to be covered later). In order to eliminate the deviation as much as possible, a process known as 'Swing ship' is carried out, whereby the ship is swung through the points of the compass and during the process the deviation is reduced to a minimum by adding permanent magnets, flinders bars and soft iron spheres, details are then recorded on a deviation chart, (updated at regular intervals).

### **Example of a Binnacle**

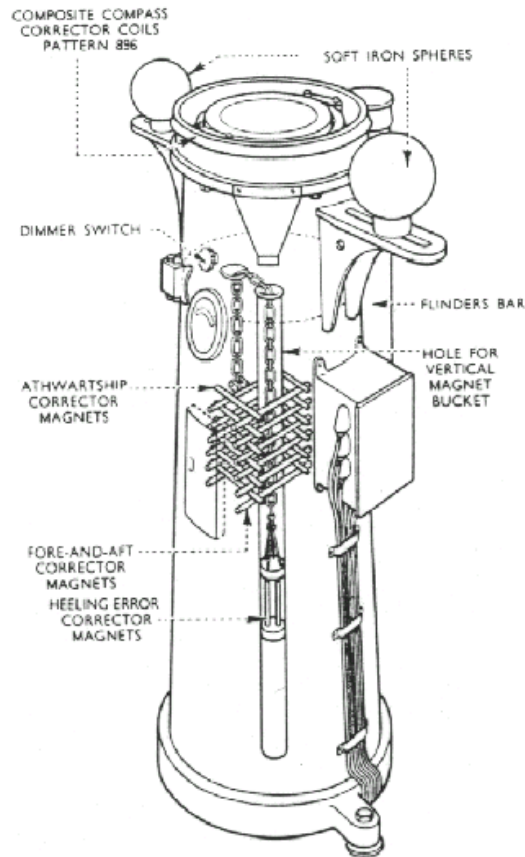

d) **Boats Magnetic Compass.** These are similar to or a smaller version of the Ship's Magnetic Compass. The compass is housed in a non-magnetic container often fitted with a cover. When used in a boat it should be placed with the 'lubbers line' in the fore-and-aft line of the boat and as far away as possible from the engine and other magnetic items. Small magnetic compasses are affected by metal objects such as watches, coins and bunches of keys which may cause inaccuracies in bearings.

Whenever a course is steered by eye the corresponding compass course should be noted and recorded, due allowance being made for the effects of wind and current so that in the event of fog or reduced visibility a correct course may be steered by compass.

The best way to take a bearing of an object from a boat is to point the bow of the boat at the object, taking care to have sufficient room to manoeuvre, then read off the compass card.

### Example of a Boats Magnetic Compass

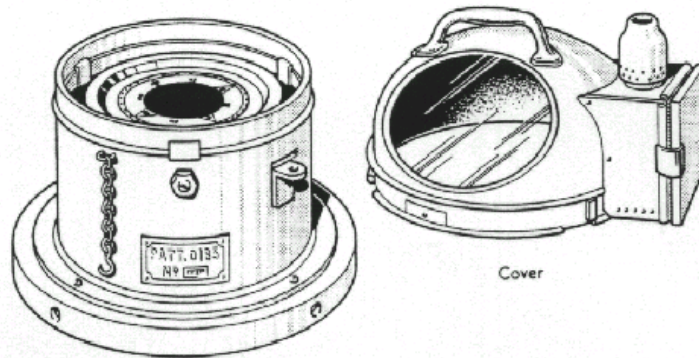

#### 0902.3 Relative Bearings

- a) For General Relative Bearings see Chapter 1.
- b) A greater degree of accuracy in relative bearings is obtained by expressing them in terms of degrees from ahead on each side of the ship. The horizon is divided into degrees from zero (right ahead) to 180 (right astern). Those on the starboard side are called green and those on the port side red. Thus in the picture below, the sailing vessel bears **red 40** and the steamship bears **green 130**. (The word 'degrees' is always omitted)

#### Red and Green Relative Bearings

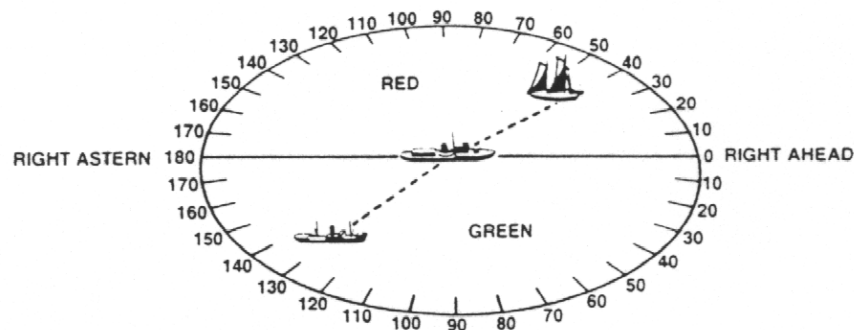

#### 0902.4 Compass Bearings

The bearing of an object from the ship may be given relative to **True** or **Magnetic** North. If it is a gyro-compass the horizon is divided into 360 degrees from True North (the Meridian), whilst a magnetic compass is divided into 360 degrees from Magnetic North.

The bearing of an object can be obtained from the Compass a bearing repeater (known as a Pelorus) or hand bearing compass by sighting along an imaginary line joining the centre of the compass card to the object and reading the graduations on the edge of the card, which is cut by the line of sight. To make bearings easy, the compass is fitted with an Azimuth Circle, which has a 'V' sight and a prism whereby the bearing is reflected and magnified, this direction or bearing is known as a Compass Bearing.

In the illustrated diagram the bearing of a church is obtained by lining up the church with the 'V' shaped sighting device. The bearing is then read off as 355 degrees.

This bearing could then be plotted onto the chart by using a parallel ruler which ensures an accurate transfer of the bearing measured from the compass rose to the position line through the mark (the church).

### ***Taking a Compass Bearing***

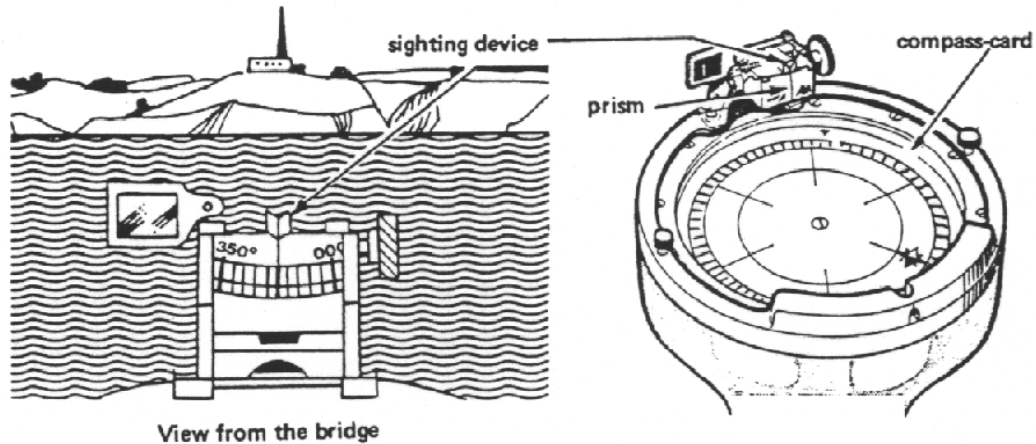

## **0903 COMMON MARKINGS ON A CHART**

### **0903.1 Scale**

Charts are issued to cover large or small areas of the seas and Coastal Regions of the land.

A chart which represents a small area is called a '**Large Scale Chart**' and one which covers a large area is called a '**Small Scale Chart**'. The terms Large or Small scale refer to the ratio between the size of details shown on the chart and their actual size. If, for example the scale of a chart is shown as 1/12500, it means that the details shown on the chart have been reduced 12,500 times. When approaching land, Large Scale Charts are used and finally, when entering harbour, the largest scale charts called Plans are used.

### **0903.2 Depth Markings**

The depths shown on a chart are related to an arbitrary level of the sea called Chart Datum, which is a low water level which the tide will seldom fall beyond. In the area covered by the chart, the depths shown on the charts are usually in metres, but where the depth is under 20 metres, it is indicated in metres and decimetres.

### **0903.3 Rocks**

Rock that does not cover height above high water.

Rock which covers and uncovers height above Chart Datum, where known.

Rock awash at the level of Chart Datum.

Rock over which the depth is unknown but is considered dangerous to navigate.

Dangerous under water rock of a known depth.

***For diagrams see Section IK of Chart 501 I (1994)***

### **0903.4 Bottom**

S = Sand

f = fine

c = coarse

M = Mud  
Sh = Shells  
St = Stones  
Wd = Weed  
bk = Broken  
R = Rock  
P = Pebbles

**For further details see Section IJ of Chart SOI I (1994)**

#### **0903.5 Wrecks**

Wreck which does not cover, height above Height Datum  
Wreck which covers and uncovers, height above Chart Datum  
Wreck submerged, depth unknown (ditto Known)  
Wreck showing any part of hull or superstructure at Chart Datum  
Wreck over which depth has been obtained by sounding only  
Wreck of which mast and/or funnels visible at Chart Datum  
Wreck which has been swept by wire to depth shown  
Wreck depth unknown which is considered dangerous to surface navigation  
Wreck depth unknown which is not considered dangerous to surface navigation

**For diagrams see Section IK Chart 501 I (1994)**

#### **0903.6 Lights**

Characteristics - the nature of the beam exhibited by a light is known as its characteristic, of which there are four main types, namely:

- a) **Fixed (F)** - a light which appears continuous and steady to an observer whose position remains unchanged in relation to it.
- b) **Flashing (Fl)** - a light showing intermittently with regular periodicity. Lights in which the duration of light in each period is shorter than the total duration of darkness.
- c) **Occulting (OCC)** - a light in which the total duration of light in each period is longer than the total duration of darkness and in which the intervals of darkness occultation's are usually all of equal duration.
- d) **Alternating (AL)** - a continuous steady light which shows a change of colour

**For all details of lights see Section IP of Chart 5011 (1994)**

#### **0903.7 Compass Rose**

Most charts have printed on them one or more Compass Roses from which a line of bearing can be drawn with the aid of a parallel ruler. Each Rose has an inner and outer circle of graduations; the outer circle shows true directions and the inner circle shows magnetic directions for a stated year. The variation that year and its annual change is indicated on this circle.

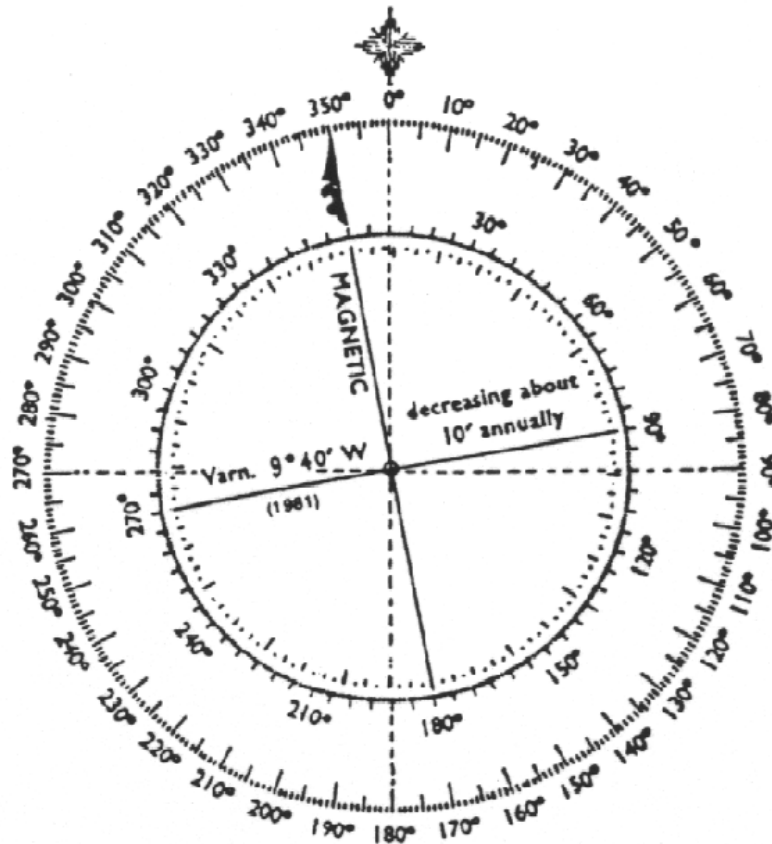

## 0904 VARIATION AND DEVIATION

### 0904.1 Variation

This is the angular difference between True North and Magnetic North. The True or geographical North Pole is a point where the meridians of Longitude meet. The Magnetic North is at present situated in the Hudson Bay area of Canada, this being the pole to which the Magnetic Compass relates, (does not point at the North Magnetic pole directly) with the variation being dependant upon the location of the observer on the earth's surface. Variation for an area on a given date is shown inside the Compass rose on the chart.

#### Example of Variation

<u>Magnetic Direction</u>	<u>Variation</u>	<u>True Direction</u>
Position A 130°M	20°W (- magnetic best)	110°
Position B 090°M	20°E (+ magnetic least)	110°

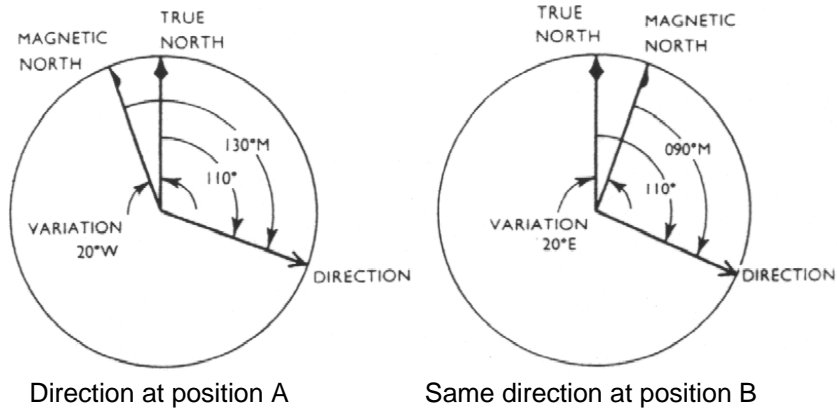

**0904.2 Deviation**

The needle of the magnetic compass aligns itself to the magnetic field by which it is influenced.

On a boat, this field has two components, the earth's magnetic field, (variation) and the field created by any electrical equipment or ferrous metal in the boat. (Deviation)  
Deviation varies according to the Ship's Head.

**Example of Deviation**

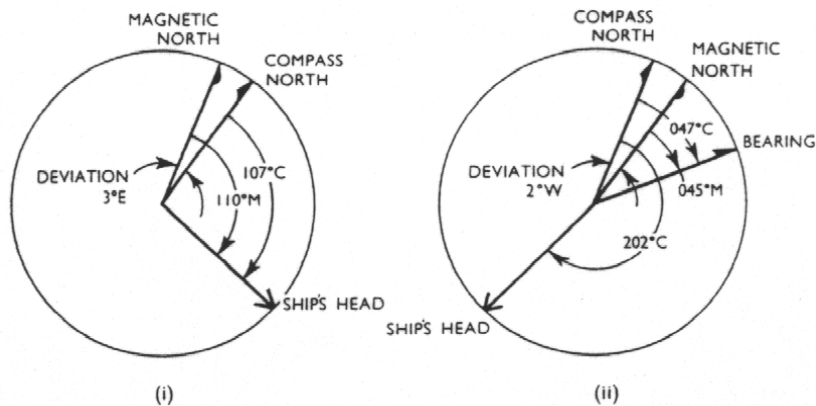

Ship's head or course, by  
Compass 107°C  
Deviation for 107°  
**(compass least - add)** 3°E  
Ship's head or course,  
magnetic 110°M

Bearing of an object, by  
compass 047°C  
Ship's head 202°C  
Deviation for 202°  
**(compass best - subtract)** 2°W  
Bearing of the object,  
magnetic 045°M

**Example of a Deviation Card (Not related to the previous examples)**

Ships Head (Compass)	Deviation	Ships Head (Magnetic)
000°	2° W	358° (M)
010°	4° W	006° (M)
020°	5° W	015° (M)
030°	7° W	023° (M)
040°	9° W	031° (M)

Ships Head (Compass)	Deviation	Ships Head (Magnetic)
180°	0° W	180° (M)
190°	3° E	193° (M)
200°	5° E	205° (M)
210°	7° E	217° (M)
220°	9° E	229° (M)

050°	11° W	039° (M)
060°	12° W	048° (M)
070°	13° W	057° (M)
080°	14° W	066° (M)
100°	12° W	088° (M)
110°	11° W	099° (M)
120°	10° W	110° (M)
130°	9° W	121° (M)
140°	8° W	132° (M)
150°	7° W	143° (M)
160°	5° W	155° (M)
170°	3° W	167° (M)

230°	11° E	241° (M)
240°	12° E	252° (M)
250°	13° E	263° (M)
260°	14° E	274° (M)
270°	13° E	283° (M)
280°	12° E	292° (M)
290°	11° E	301° (M)
300°	10° E	310° (M)
310°	9° E	319° (M)
320°	7° E	327° (M)
330°	5° E	335° (M)
340°	3° E	343° (M)

### 0904.3 Laying off a course

The starting point 'A' may be a fix, a Latitude and Longitude position or a bearing and distance from a given object. Place the parallel ruler on the nearest compass rose and 290 degrees, (the course being steered) on the outer circle of graduations, and for increased accuracy make sure that it also passes through 110 degrees, the reciprocal of the course. With the parallel ruler transfer this direction so as to pass through starting point 'A' and draw a line of sufficient length to show the whole run. This will be the ships course.

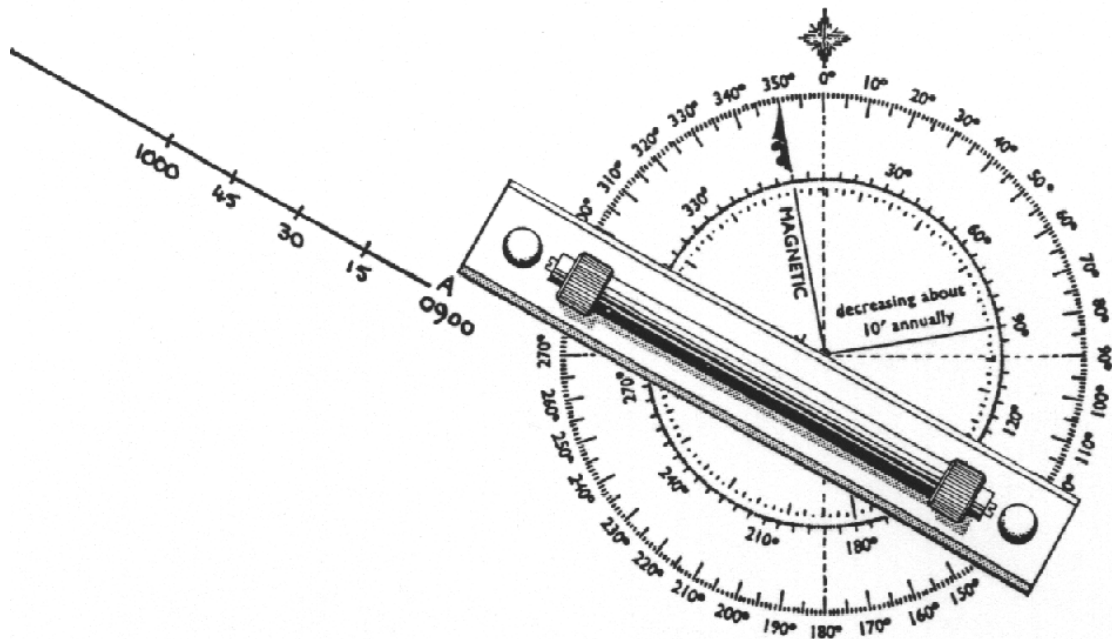

### 0904.4 Plotting a Fix

When a ships position is fixed by three bearings, the objects selected should, if possible, lie so that their bearings differ by about 60 degrees; the position lines will then make a good cut.

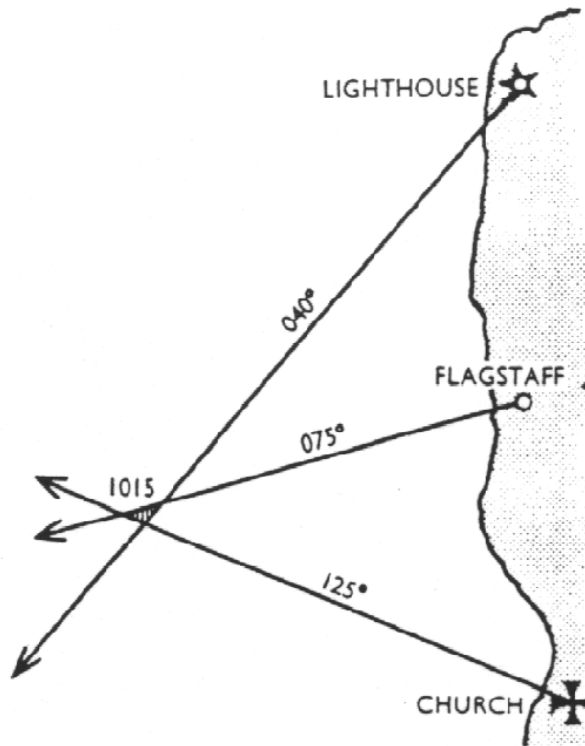

**0904.5 Dead Reckoning**

Having obtained a fix you must immediately forecast the future position of the ship. This can be illustrated by an example.

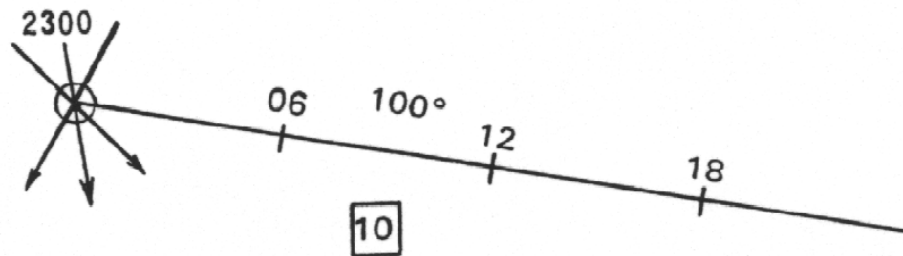

A fix obtained at 2300 is plotted on the chart. From the fix the navigator then draws a line representing the course that is being steered, in this case 100°. The ship's speed, as recorded by the ship's log, is 10 knots: this works out at 1 mile every 6 minutes. So at one mile intervals on the line he has drawn, the navigator marks the ship's forecast positions with a cross.

Note that the course being steered is written alongside the line on the chart and the speed is shown in a box. In addition, the Dead reckoning (D.R.) positions must always be accompanied by the time. Use 2-figure times except for the first DR in a new hour.

In the above example we have chosen to forecast the ship's future positions at 6 minute intervals. What interval you will use will depend on the circumstances - check this point with your instructor - but 6 minutes is a very convenient interval, allowing you to divide the ship's speed by 10. For example a ship's speed of 19 knots represents 1.9 miles



travelled every 6 minutes. Many navigators use this system, which is sometimes called the 'six minute rule'.

### 0904.6 Estimated Position

In order to have a really effective forecast, the navigator needs to make the best possible estimate of the ship's future position. Such a position is called an 'Estimated Position', and is marked thus:



In the example below, a fix was obtained at 0115 and the DR positions calculated using this fix.

A fix is subsequently obtained at 0130, as shown. You do not alter course or speed and you want to calculate the 0145 Estimated Position. This is most likely to be your chosen position:

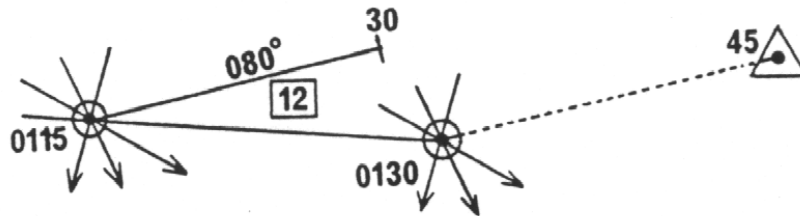

In the absence of other evidence it is more likely that the ship will continue to be carried down to the south (probably by a tidal stream) and therefore we would say that most navigators would assume that the speed and direction of the ship **over the ground** from 0115 to 0130 will probably be continued from 0130 to 0145 as shown below.

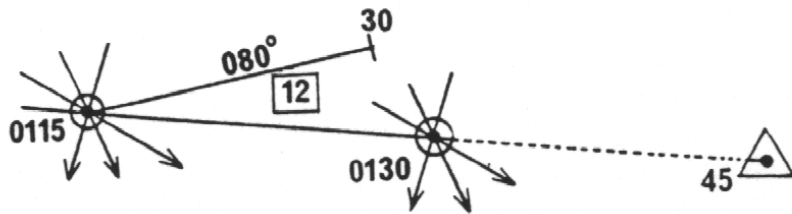

In the example below the DR position for 2020 has been forecast and a fix for 2020 obtained. For the purposes of the exercise we will assume that the difference between the two (in this case the DR position for 2020 and the fix for 2020) is attributable to the force of the tidal stream. (For large displacements this is the most likely cause).

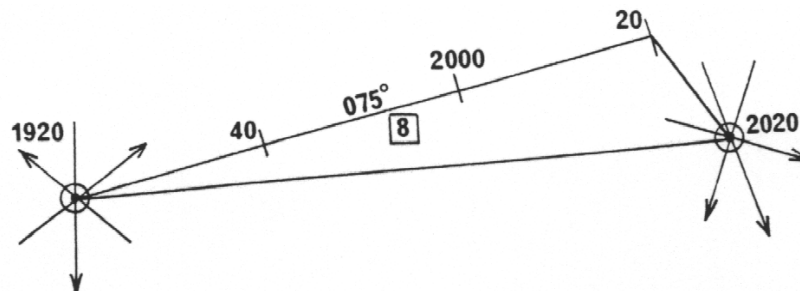

To understand how tidal stream effects the ship, do not think of it as pushing the ship

somewhere -this implies resistance. Picture the whole surface of the sea moving in a certain direction at a certain rate and carrying the ship along with it like a man walking up an escalator, or on a Travolator strip at an airport. Bearing in mind the effect of the tidal stream, you can see that the course steered by the ship is different from the actual track of the ship over the ground.

Which line of the diagram show the actual track of the ship?

The answer is - the line joining the 1920 fix to the 2020 fix.

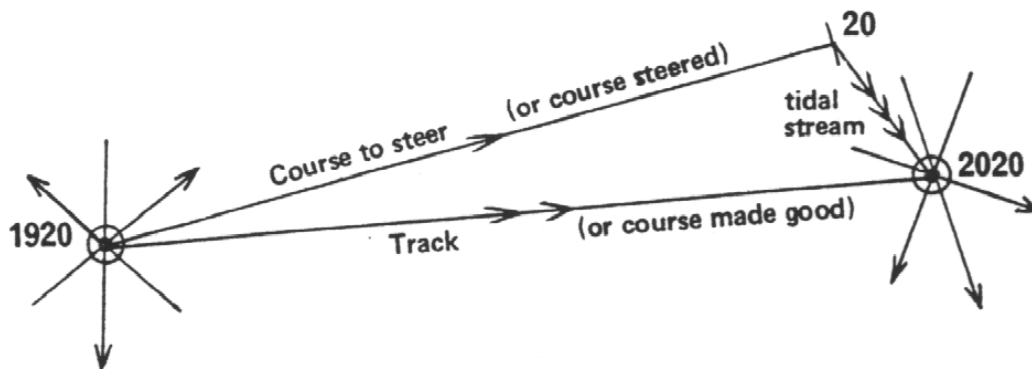

The three lines can be treated as vector, making up a vector triangle. It will be useful at this point to learn how they are referred to and the conventions used to distinguish them.

Course to steer (or course steered) - this is the line giving the DR positions and is marked with a single arrow.

Track (or course made good) - this is the line representing the ship's track over the ground and is marked with a double arrowhead.

Tidal Stream - the line representing the tidal stream is marked with three arrowheads.

If we assume that the force moving the ship from its DR position is tidal stream we can find the direction and rate of the tidal stream, given the course steered and the ship's track.

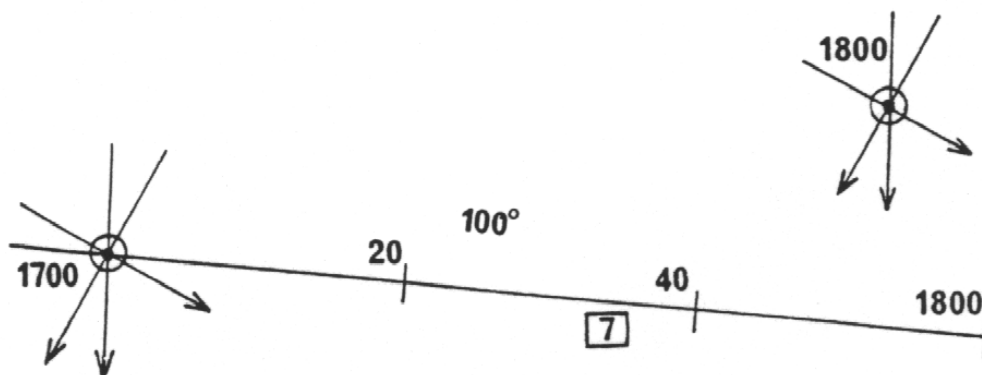

The direction of the tidal stream can now be found - by inspection it is approximately  $340^\circ$ . It can be measured accurately by using parallel rulers and a compass rose. The

rate can be found by measuring the length of the tidal stream vector, say 2 miles - this means a rate of 2 knots if your vector triangle is for one hour as in this example.

Vector triangles can be used to find not only the tidal stream, but also the track and the course to steer to maintain a course allowing for tidal stream.

**GIVEN**

**FIND**

Course steered and ship's track

Tidal Stream

Course steered and tidal stream

Ship's track

Ship's track and tidal stream

Course to steer

**0904.7 Transits**

This method is used for checking the accuracy of a compass. It is also the simplest method of establishing a position without the aid of a compass or a chart. A transit is achieved by lining up two or more fixed objects in each of two different directions. The resultant crossing point of the two transit lines will represent your boat's position.

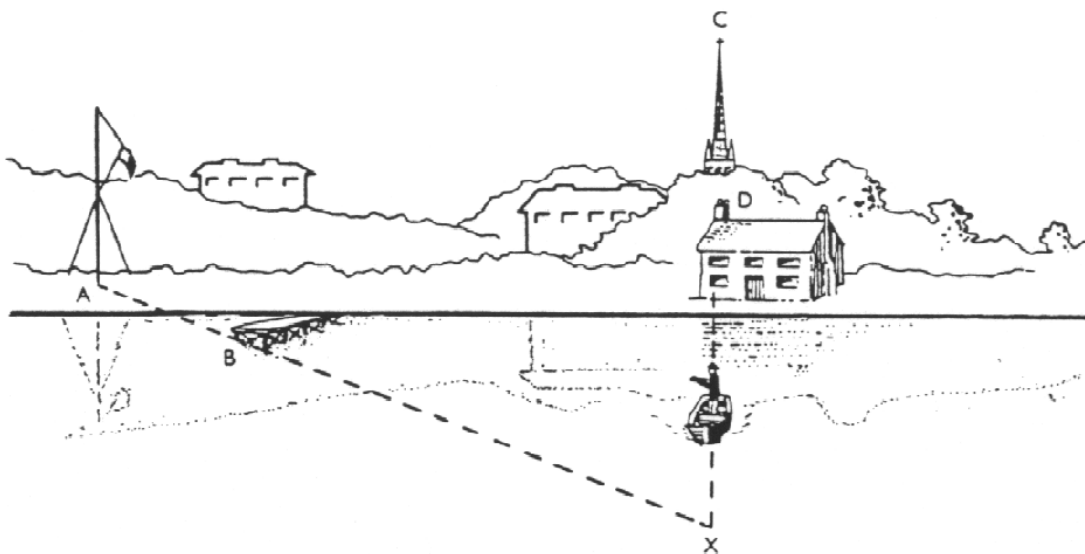

## 0904.8 Plotting a Position using Latitude and Longitude

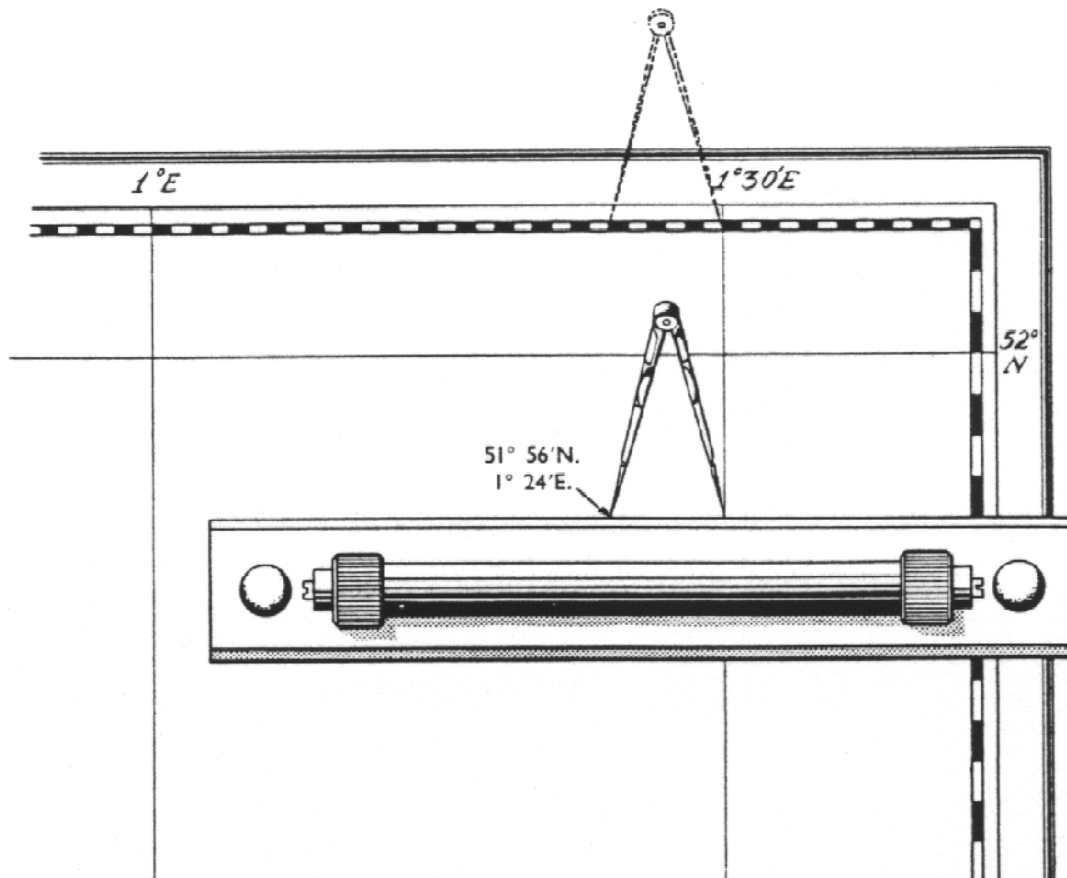

## 0905 TIDES

### 0905.1 Causes of Tides

The periodic rising and falling of the sea levels constitute what are known as tides.

**Local Tides** : Those tides around Great Britain, are semi-diurnal in character, i.e. two High waters and two Low waters daily.

**Springs and Neaps** : The combined tide raising forces of the moon and the sun have their greatest effect when the sun and moon are in line with the earth, i.e. at new and full moons. And their least effect when they are at right angles to each other, i.e. first and last quarters.

Shortly after Full and New Moon a locality will experience its highest High Waters and lowest

Low Waters of that lunar month. These tides are called **Springs**.

Conversely around the times of First and Last Quarters of the moon, the lowest High Waters and the highest Low Waters will be experienced. These tides are called **Neaps**.

### Examples of Spring and Neap tides

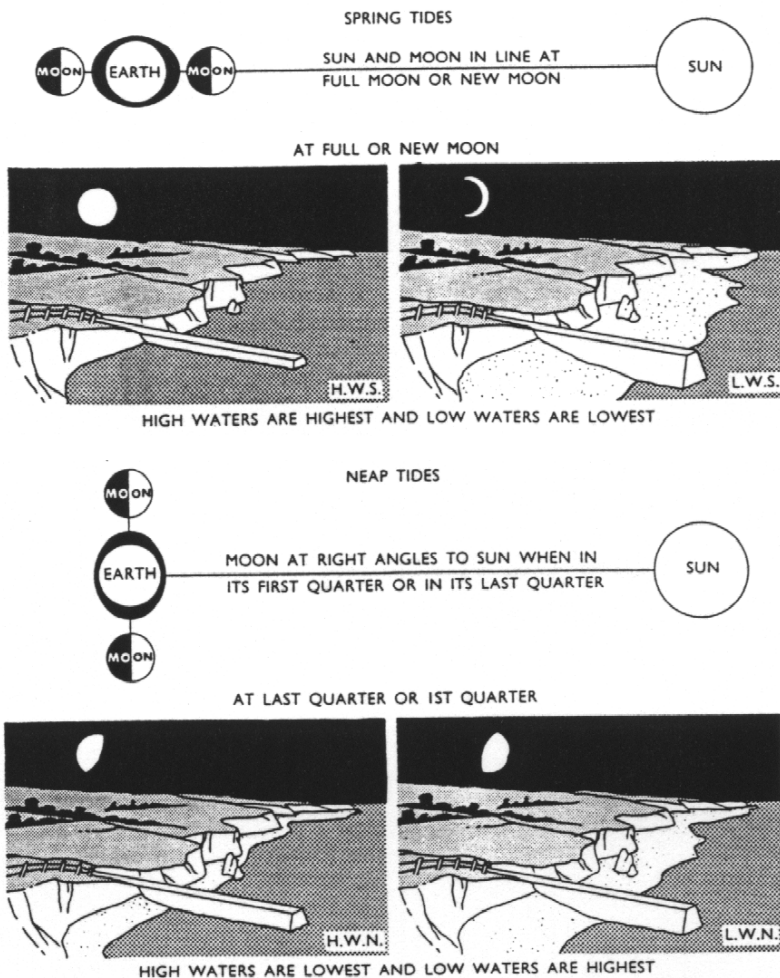

#### 0905.2 The Stand and Slack Water

The period at High or Low Water during which no rise or fall can be detected is also known as *The Stand*.

**SLACK WATER** is the period when there is no horizontal movement of water as a tide is about to turn from Ebb to flood or Flood to Ebb.

N.B. Slack water and the Stand frequently do not coincide.

### **Spring and Neap Tides in the British Isles relative to the phases of the Moon**

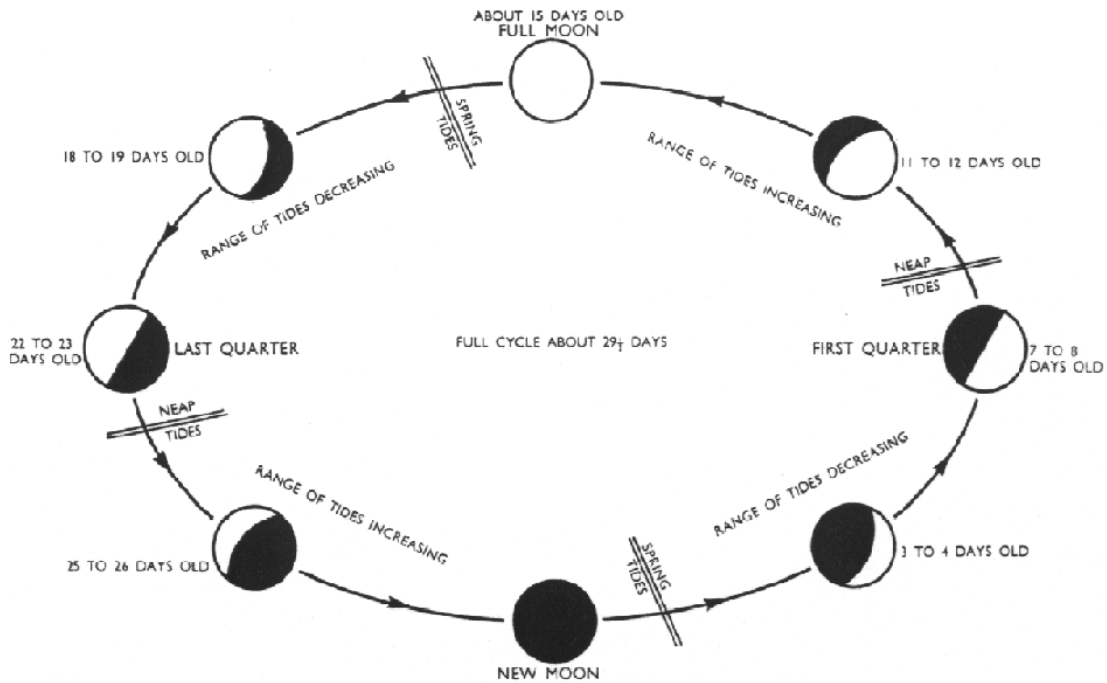

#### **0905.3 Tidal Streams**

Although the tidal wave does not carry the water along with it, its passage along the coast does produce horizontal movements of water called **Tidal Streams**, which flow in and out of harbours along the coast. The Incoming tidal stream is known as the Flood and the Outgoing tidal stream the **Ebb**.

**Weather Going streams** : whenever a strong stream is flowing against the wind, an uncomfortably short, steep sea is raised. This usually abates noticeably at the turn of the tide. Such conditions call for extra care in handling boats and in tending boats secured alongside a ship in a tideway.

#### **0905.4 The Tidal Wave**

In many cases the tidal wave appears to advance from the centre of an ocean along the surrounding coasts. The advance of the tidal wave around the coasts of Great Britain has a period of oscillation of about 12 hours and moves approximately as follows :

- at zero + 2 hours it arrives off the coast of Portugal;
- at zero + 3 hours it arrives off the western coast of France;
- at zero + 4 hours it arrives off Land's End.

At Land's End part of the tidal wave travels up the English Channel and reaches the Strait of Dover at zero + 11 hours, while the remainder continues northward up the West coast of Ireland until:

- at zero + 9 hours it arrives west of the Orkney Islands, and then passes into the North Sea;
- at zero + 12 hours it arrives off Peterhead;
- at zero + 24 hours it arrives off Harwich.

Off Harwich this tidal wave meets its successor, which set out from mid-Atlantic at about zero + 12 hours and had travelled up the Channel through the Strait of Dover in the intervening period.

**Approximate advance of a tide-wave around Great Britain**

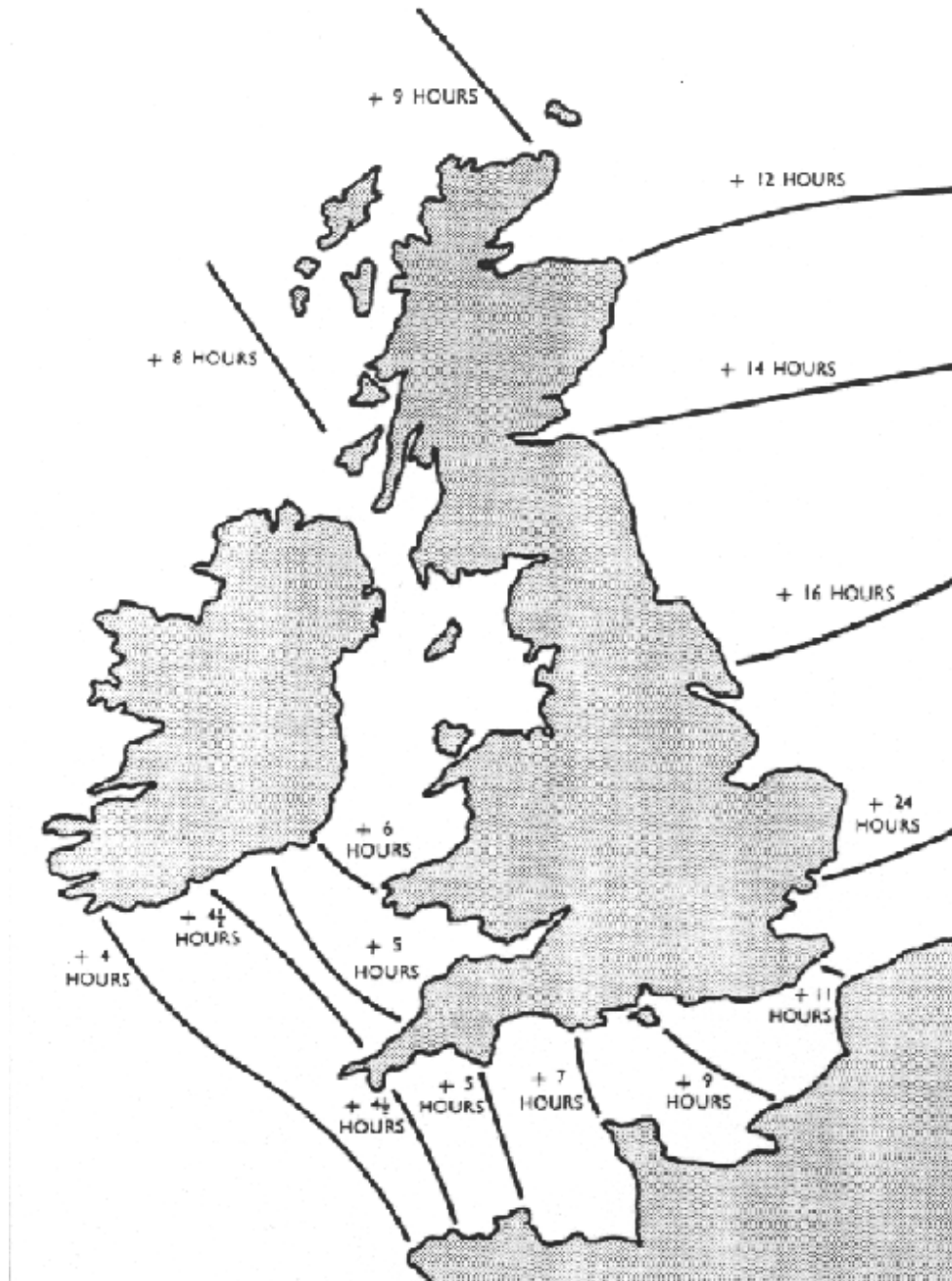

**0905.5 Calculation of Tides by using the Twelfths Rule**

Before we can apply the calculations to work out tidal depths at any given time we need to know what the tidal range is for the given area. The range of any tide is the difference

between the levels of successive high and low waters. Admiralty Tide Tables provide information on the tidal range for a given area, which will provide figures with which to work on,  
 e.g. Times and Heights of High and Low Water on a given date.

The twelfths rule assumes that the duration of the tide is always six hours, a fact that is not always true and so a slight error will exist. The rate of flow of the tide is not constant per hour, but increases towards mid-tide and decrease again towards the last hour. If we know the rate of change of flow, we can then calculate the depth at any given time.

**Sequence**

- 1st hour - it rises or falls 1/12 of the range
- 2nd hour - it rises or falls 2/12 of the range
- 3rd hour - it rises or falls 3/12 of the range
- 4th hour - it rises or falls 3/12 of the range
- 5th hour - it rises or falls 2/12 of the range
- 6th hour - it rises or falls 1/12 of the range

**The Range of the Tide**

Example: To find the range

High Water 0600		height 7.8 metres (a)
Low Water 1210		height 3.0 metres (b)
Therefore the range	=	4.8 metres (a - b)
1/12 of the range	=	0.4 metres

Example: To find the depth of water at 0800 working from High water:

High Water 0600		height 7.8 metres
Low Water 1210		height 4.8 metres
Range	=	3.0 metres
1/12 range	=	0.4 metres
number of 12ths req'd		3 (2 hours after High Water)
		-----
		1.2 metres (0.4 x 3)
		-----
Subtract for High Water		7.8 metres
		1.2 metres
		-----
<i>Total height to be added to the Charted depth</i>	=	<b>6.6 metres</b>

**0905.6 Chart Datum**

Chart datum is the level below which depths are given on a chart, and above which the height of the tide is measured; the height of the tide at any moment must therefore be added to the charted depth to give the actual depth or sounding. The Chart datum is selected during the initial survey of an area and varies from place to place depending upon the range of the tide in the area. By international agreement, the Chart datum should be a plane so low that the tide will not frequently fall below it. The heights of features never or rarely covered by the sea are referred to the high water plane.



In the example below the tide pole is graduated in metres and decimetres, situated where the charted depth is 1.1 metres on a day when the rise of the tide is, say 5.7 metres.

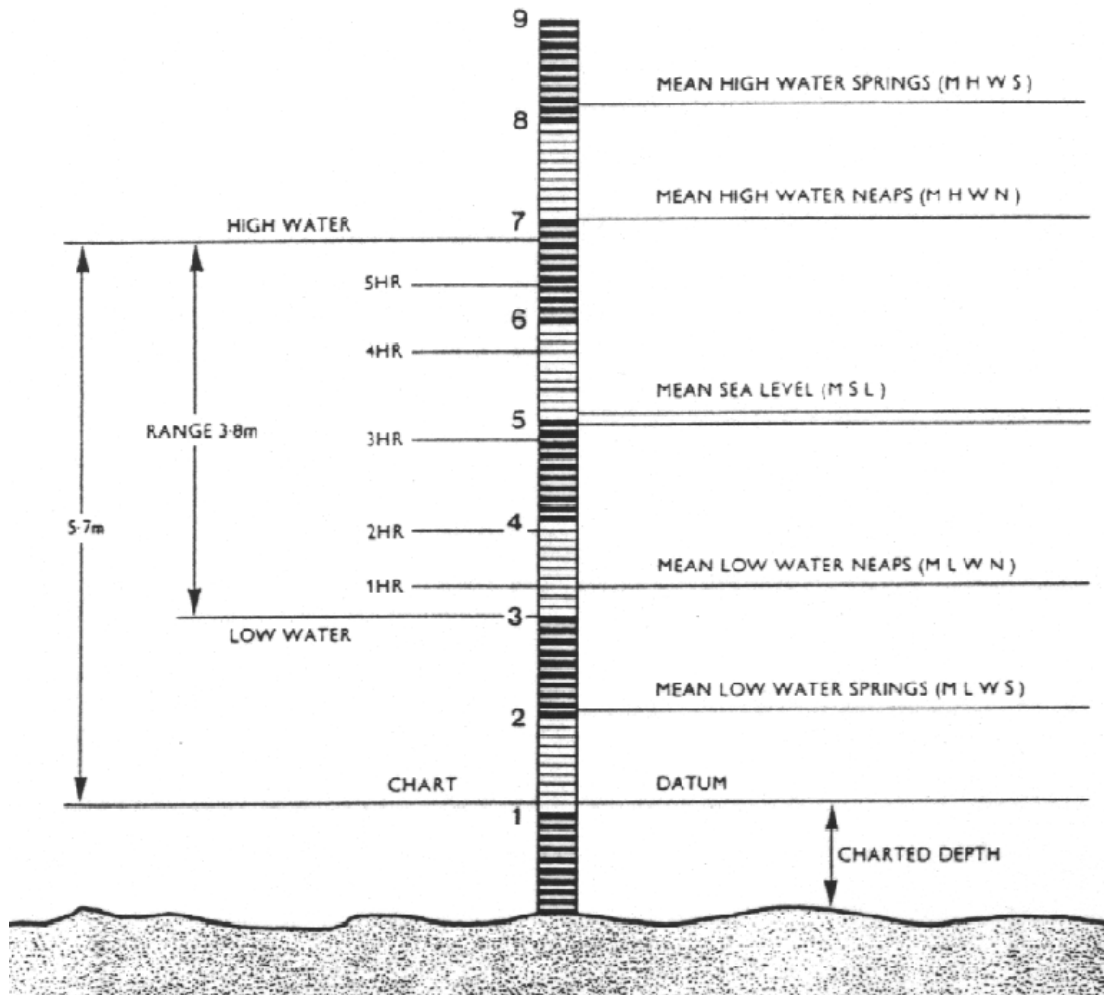

### 0905.7 Tide Tables

The Admiralty Tide Tables give daily predictions of the times and heights of high and low water for a selected number of Standard Ports. For all other ports, called Secondary Ports, sufficient information is given in the back of the Tide Tables to enable the times and heights of tides to be calculated. The computed predictions are based on the analysis of one year's observations at least, and can be taken as correct for all occasions except for abnormal weather conditions. The time used in the Admiralty Tide tables is always local time. The amount that you have to add or subtract to get Greenwich Mean Time is always shown against 'Time Zone' on the top left-hand corner of the page.

### Example of a Tide Table for Margate

#### ENGLAND, EAST COAST - MARGATE

LAT 51°24'N      LONG 1°23'E

TIMES AND HEIGHTS OF HIGH AND LOW WATERS

YEAR 1985

TIME ZONE GMT		TIMES AND HEIGHTS OF HIGH AND LOW WATERS																					
		JANUARY				FEBRUARY				MARCH				APRIL									
TIME	M	TIME	M	TIME	M	TIME	M	TIME	M	TIME	M	TIME	M	TIME	M								
1	0041	1.7	16	0052	1.4	1	0155	1.6	16	0315	1.2	1	0553	3.7	16	0131	1.3	1	0152	1.5	16	0356	0.8
	0653	3.9		0700	4.3		0806	3.7		0928	4.1		1221	1.6		0744	3.9		0815	3.8		1010	4.3
TU	1333	1.3	W	1351	0.8	F	1429	1.4	SA	1549	1.2	F	1839	3.7	SA	1413	1.5	M	1426	1.6	TU	1616	1.3
	1948	3.9		1958	4.1		2051	3.9		2159	4.1					2016	3.8		2046	3.9		2212	4.2
2	0149	1.6	17	0212	1.3	2	0303	1.5	17	0433	1.0	2	0103	1.7	17	0307	1.1	2	0311	1.2	17	0449	0.6
	0758	3.9		0812	4.2		0917	3.8		1044	4.2		0713	3.6		0925	4.0		0928	4.2		1058	4.4
W	1430	1.2	TH	1458	0.9	SA	1528	1.3	SU	1654	1.1	SA	1341	1.6	SU	1538	1.4	TU	1538	1.3	W	1659	1.1
	2047	4.0		2105	4.2		2153	4.1		2259	4.2		2005	3.7		2142	4.0		2146	4.2		2255	4.3
3	0250	1.5	18	0324	1.2	3	0406	1.3	18	0530	0.7	3	0223	1.5	18	0423	0.8	3	0416	0.8	18	0527	0.6
	0837	4.0		0927	4.2		1019	4.1		1139	4.3		0844	3.7		1034	4.3		1026	4.5		1134	4.5
TH	1521	1.2	F	1600	0.9	SU	1628	1.2	M	1742	1.1	SU	1456	1.5	M	1644	1.2	W	1634	1.0	TH	1729	1.0
	2139	4.2		2210	4.2		2247	4.3		2344	4.3		2121	3.9		2242	4.2		2237	4.5		2329	4.4
4	0343	1.3	19	0430	1.0	4	0504	1.0	19	0615	0.6	4	0339	1.3	19	0518	0.6	4	0506	0.5	19	0556	0.7
	0952	4.1		1038	4.3		1112	4.3		1222	4.4		0955	4.0		1125	4.4		1115	4.8		1204	4.5
F	1607	1.1	SA	1657	1.0	M	1722	1.0	TU	1818	1.0	M	1604	1.3	TU	1729	1.1	TH	1720	0.8	F	1754	0.9
	2227	4.3		2306	4.3		2334	4.5					2220	4.2		2327	4.3		2320	4.8		2357	4.5
5	0433	1.2	20	0527	0.8	5	0556	0.8	20	0622	4.4	5	0442	0.9	20	0558	0.6	5	0551	0.2	20	0619	0.7
	1041	4.3		1137	4.4		1200	4.6		0650	0.5		1052	4.4		1205	4.5		1201	4.9		1229	4.5
SA	1652	1.0	SU	1744	1.0	TU	1808	0.8	W	1259	4.5	TU	1702	1.0	W	1800	1.0	F	1803	0.6	SA	1819	0.9
	2312	4.5		2353	4.4		0			1848	0.9		2309	4.5					0				
6	0520	1.0	21	0617	0.7	6	0019	4.7	21	0055	4.5	6	0534	0.6	21	0001	4.4	6	0003	4.9	21	0027	4.6
	1127	4.4		1225	4.5		0642	0.5		0723	0.5		1142	4.7		0629	0.6		0635	0.1		0645	0.7
SU	1737	0.9	M	1825	0.9	W	1245	4.7	TH	1330	4.5	W	1749	0.8	TH	1236	4.5	SA	1245	5.0	SU	1253	4.5
	2354	4.6					1852	0.7		1919	0.9		2354	4.7		1825	0.9		1845	0.5		1849	0.8
7	0607	0.9	22	0034	4.5	7	0100	4.6	22	0126	4.6	7	0621	0.3	22	0029	4.5	7	0046	5.0	22	0056	4.6
	1212	4.5		0659	0.6		0726	0.4		0752	0.6		1227	4.8		0655	0.6		0717	0.1		0712	0.8
M	1821	0.9	TU	1309	4.6	TH	1330	4.8	F	1359	4.5	TH	1831	0.6	F	1303	4.5	SU	1327	4.9	M	1317	4.5
				1903	0.9		1934	0.7		1948	0.9					1850	0.9		1927	0.5		1921	0.8
8	0035	4.7	23	0112	4.6	8	0141	4.9	23	0157	4.6	8	0035	4.9	23	0057	4.6	8	0130	5.1	23	0126	4.6
	0652	0.7		0740	0.5		0809	0.3		0822	0.6		0703	0.2		0720	0.6		0759	0.2		0738	0.9
TU	1255	4.7	W	1348	4.6	F	1413	4.8	SA	1427	4.4	F	1310	4.9	SA	1327	4.5	M	1409	4.8	TU	1342	4.5
	1903	0.9		1940	0.9		2015	0.7		2019	0.9		1912	0.6		1919	0.8		2009	0.6		1952	0.9
9	0116	4.7	24	0147	4.5	9	0220	4.9	24	0226	4.6	9	0116	5.0	24	0126	4.6	9	0215	5.0	24	0157	4.5
	0737	0.8					0851	0.3					0116	5.0		0745	0.7		0842	0.5		0806	
W	1338	4.7														1351	4.6		1450	4.6		1417	
																1448							

### 0905.8 Estimating Tidal Strength and Direction

Clear indication of the set or direction of the stream is given by ships/boats riding head on to it, or buoys canting away from it, (except the spar buoy which is moored so that its staff inclines upstream or down wind whichever is the stronger), or by the ripple of water in the wake of the moored object such as a buoy. Inshore indicators are given by drifting flotsam and by the ripple in the wake of posts or piles. (By noting such indications coxswains of boats can save themselves much time and labour and avoid possible damage to their craft when coming alongside).

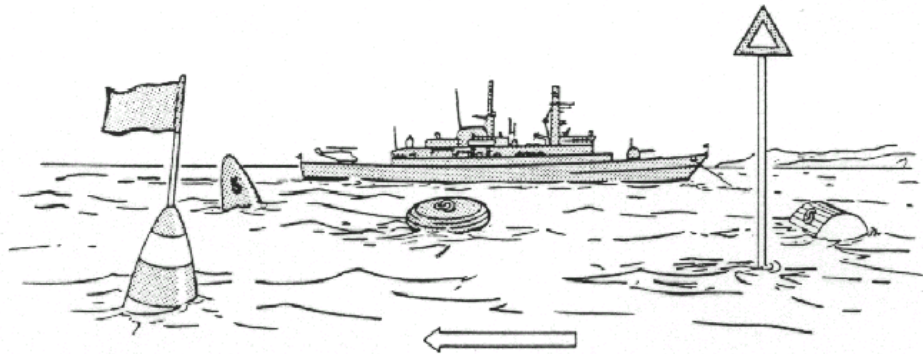

## 0906 RULE OF THE ROAD

### 0906.1 Basic Rule of the Road

Vessels sailing on the high seas have to abide by certain rules, otherwise there would be many collisions. These rules are called ***The International Regulations for Preventing Collisions at Sea*** or ***'Rule of the Road'***. The full regulations can be found in the **Admiralty Manual of Seamanship volume II (1981)** and a ***Seaman's Guide to the Rule of the Road (BR 453)***.

***They are not available in the new Admiralty Manual of Seamanship (BR 67) dated 1995.)***

### 0906.2 General Definitions

The word ***'vessel'*** includes every description of watercraft including non-displacement (Basics) craft and seaplanes, used or capable of being used as a means of transport on water.

The term ***'power-driven vessel'*** means any vessel propelled by machinery.

The term ***'sailing vessel'*** means any vessel under sail provided that propelling machinery, if fitted, is not being used.

The word ***'underway'*** means that a vessel is not at anchor, or made fast to the shore, or aground.

The term ***'restricted visibility'*** means any condition, in which visibility is restricted by fog, mist, falling snow, heavy rainstorms, sandstorms or any other similar causes.

Every vessel shall at all times maintain a proper look-out.

Keep to the starboard side of any narrow channel.

### 0906.3 Assessing the Risk of Collision.

When two vessels appear to be on converging courses the possibility of collision depends on their relative courses and speeds. The only certain way of determining whether the risk of collision exists is to take a compass bearing of the other vessel. If the bearing ***does not alter***, or ***alters only slightly***, then the risk of collision exists. If the bearing ***draws forward***, then the other vessel should pass ahead; if the bearing ***draws aft***, she should pass astern.

If a compass is not available, the relative bearing of the other vessel gives an indication of the risk of collision provided that your own vessel **remains on a steady course**.

### 0906.4 Steering and Helm Orders

As Quartermaster or Helmsman at sea, you will be required to carry out various Helm Orders as given by the Officer of the Watch.

Before handing over the wheel the outgoing helmsman will confirm the course to steer, the engine speed and revolutions set with the incoming helmsman then the following report is made:

Helmsman calls: ***"Bridge - Wheelhouse"***

OOW Reply: ***"Bridge"***

Helmsman calls: **"Permission for ...Rank and Name..... to take the wheel sir"**

OOW Reply: **"Very Good"**

New Helmsman takes over the wheel ensuring that the correct course is maintained, then makes a report to the bridge.

Helmsman calls: **"Bridge-Wheelhouse"**

OOW Reply: **"Bridge"**

Helmsman reports: **"... Rank and Name... on the wheel Sir, course to steer ... e.g. 175 degrees, both/engine showing half ahead, 100 (one zero zero) revolutions set"**.

OOW Reply: **"Very Good"**

Helmsman must maintain the course as accurately as possible while making the report. In rough weather a greater degree of care should be exercised as greater amounts of wheel may be required to keep the ship on course.

When is it necessary to alter course or change the engine or revolution mode the OOW will call to the Helmsman with the order, the helmsman confirms the order, carries it out and then reports back to the OOW that the order has been carried out. Here is a simple example for altering course:

OOW orders: **"Starboard Fifteen" (15).**

Helmsman replies: **"Starboard Fifteen"** then turns the wheel to apply 15 degrees to starboard.

Helmsman reports: **"Fifteen of Starboard wheel on Sir"** (the word degrees is omitted).

OOW orders: **"Midships"**.

Helmsman replies: **"Midships"** then turns the wheel back to the midships position.

Helmsman reports: **"Wheel Amidships Sir"**.

OOW Orders: **"Port Ten"**.

Helmsman replies: **"Port Ten"** then applies 10 degrees of port wheel.

Helmsman reports: **"Ten of Port wheel on Sir"**.

OOW orders: **"Midships"**

Helmsman replies: **"Midships"** then returns to the midships position.

Helmsman reports: **"Wheel Amidships Sir"**.

If the OOW has manoeuvred the ship onto its new chosen course or is very close to it;

OOW orders: **"Steer Two Zero Zero"**.

Helmsman replies: **"Steer Two Zero Zero"** and when he is on the chosen course;

Helmsman reports: **"Course Two Zero Zero Sir"**.

OOW replies: **"Very Good"**.

Or if the OOW has not manoeuvred the ship onto its new chosen course and is within a few degrees - after Helmsman reports "Wheel Amidships Sir"

OOW orders: **"Steady"**

Helmsman reports: **"Course Two Zero Zero Sir"** this will be the compass heading the ship currently lies on.

OOW orders: "**Very Good, Steer Two Zero Zero**".

The helmsman then maintains the course until ordered to change by the Officer of the Watch.

#### **0906.5 Overtaking Rules**

- a) Any vessel overtaking another shall keep out of the way of the vessel being overtaken.
- b) A vessel shall be deemed to be overtaking when coming up with another vessel from a direction more than 22.5 degrees abaft her beam.(i.e. in the stern light area)
- c) When a vessel is in any doubt as to whether she is overtaking another, she shall assume that this is the case and act accordingly.
- d) Any subsequent alteration of the bearing between the two vessels shall not make the overtaking vessel a crossing vessel within the meaning of these rules or relieve her of her duty of keeping clear of the overtaken vessel, until she is finally past and clear.

#### **0906.6 Restricted Waters (Narrow Channels)**

- a) A vessel proceeding along a course of a narrow channel or fairway, shall keep as near to the outer limit of the channel or fairway, which lies on her starboard side as is safe and practicable.
- b) A vessel of less than 20 metres in length, or a sailing vessel, shall not impede the passage of a vessel, which can safely navigate only within a narrow channel or fairway.
- c) A vessel engaged in fishing, shall not impede the passage of any other vessel navigating within a narrow channel or fairway.
- d) A vessel shall not cross a narrow channel or fairway, if such crossing impedes the passage of a vessel, which can safely navigate only within such channel or fairway. The latter vessel may use the prescribed sound signal (in Rule 34(d)) see below if in doubt as to the intention of the crossing vessel.
- e) In a narrow channel or fairway when overtaking can take place only if the vessel to be overtaken has to take action to permit safe passing, the vessel intending to overtake shall indicate her intention by sounding the appropriate signal (Rule 34 (c) ) see below:

The vessel to be overtaken shall, if in agreement, sound the appropriate signal, (Rule 34(c)) see below and take steps to permit safe passing. If in doubt she may sound the signals prescribed (Rule 34(d)) see below. This rule does not relieve the overtaking vessel of her obligation under the overtaking rules.

- f) A vessel nearing a bend or an area of a narrow channel or fairway, where other vessels may be obscured by an intervening obstruction, shall navigate with

particular alertness and caution, and shall sound the appropriate signal prescribed (Rule 34(e)).

- g) Any vessel shall, if the circumstances of the case permit, avoid anchoring in a narrow channel.

## 0907 SOUND SIGNALS

### 0907.1 Manoeuvring Sound Signals - Definitions

- a) The word '*whistle*' means any sound signalling appliance capable of producing the prescribed blasts.
- b) The term '*short blast*' means a blast of about 1 second duration.
- c) The term '*prolonged blast*' means a blast of 4 - 6 seconds duration.

### 0907.2 Manoeuvring Sound Signals

- a) ***One short blast*** means: 'I am altering my course to Starboard'  
***Two short blasts*** means: 'I am altering my course to Port'  
***Three short blasts*** means: 'I am operating astern propulsion'
- b) These signals may be supplemented by the same sequence of flashes of light whilst the manoeuvre is being carried out.

Rule 34 c) When in sight of one another in a narrow channel or fairway; a vessel intending to overtake another shall indicate her intention by the following signals on her whistle :

1. ***Two prolonged blasts*** followed by ***one short blast*** means:  
**'I wish to overtake you on your Starboard side'**
2. ***Two prolonged blasts*** followed by ***two short blasts*** means:  
**'I wish to overtake you on your Port side'**
3. The vessel about to be overtaken shall indicate her agreement by sounding the following signal:  
***One prolonged blast, one short blast, one prolonged blast, one short blast***, in that order. (i.e. 'C' - Yes, Affirmative)

Rule 34 d) When vessels in sight of each other are approaching one another, and either vessel fails to understand the intentions of the other, shall sound at least **five short blasts** in rapid succession. Such a signal may be supplemented by a light signal of at least five short and rapid flashes.

Rule 34 e) A vessel nearing a bend or area of a channel or fairway, where other vessels may be obscured, shall sound **one prolonged blast** . Each signal shall be answered with **a prolonged blast** by an approaching vessel, that may be within hearing around the bend or behind an intervening obstruction.

### 0907.3 Sound Signals in Restricted Visibility

- a) A **Power Driven vessel making way** shall sound at intervals of not more than two minutes, **'One prolonged Blast'**.
- b) A **Power driven vessel under way** but stopped and making no way, shall sound at intervals of not more than two minutes, **'Two Prolonged blasts'**.(2 seconds between the blasts).
- c) A vessel **not under command**, a vessel **restricted**, a vessel **constrained by her draft**, a **sailing** vessel, a vessel engaged in **fishing** and a vessel engaged in **towing** or pushing, shall sound, at intervals of not more than two minutes, three blasts in succession, namely **'One Prolonged blast** followed by **Two Short blasts'**.
- d) A vessel **towed** or if more than one vessel is towed the last vessel of the tow, if manned, shall at intervals of not more than 2 minutes sound four blasts in succession, namely **'One prolonged blast** followed by **Three short blasts'**. When practicable, this signal shall be made immediately after the signal made by the towing vessel.
- e) A vessel **at anchor** shall at intervals of not more than one minute ring the bell rapidly for about 5 seconds. If 100 metres or more long she sounds the bell forward followed by 5 seconds on a gong aft. She may in addition sound three blasts in succession, namely **'One Short, One Prolonged** and **One short blast'** to give warning of her position and of the possibility of collision to an approaching vessel.
- f) A vessel of **less than 12 metres** in length shall not be obliged to give warning signals as prescribed for other vessels, but if she does not, shall make some other efficient sound signal at intervals of not more than 2 minutes.

### 0907.4 Signals to attract attention

If necessary to attract the attention of another vessel any vessel may make light or sound signals that cannot be mistaken for any signal authorised elsewhere within the Rules, or may direct the beam of her searchlight in the direction of the danger, in such a way as not to embarrass any vessel.

### 0907.5 Power Driven Vessel's Sound Signals

#### *Summary of Sound Signals*

- Abbreviations. ● - 1 short blast of 1-2 seconds duration
- - 1 prolonged blast of 4-6 seconds duration
- PDV - Power Driven Vessel
- ev 2 - Every 2 minutes

For vessels in sight of each other:

<b>Signal Meaning</b>	<b>Meaning</b>
<i>Whistle blast</i>	
•	I am altering course to Starboard
••	I am altering course to Port
•••	I am operating astern propulsion
- - •	I intend to overtake you on your starboard side
- - ••	I intend to overtake you on your port side
•••••	I do not understand your intentions (known as the 'wake up' signal)
-	Approaching a bend in a river
- ••	A vessel a) Not under command (NUC) b) Restricted in her ability to manoeuvre c) Constrained by her draught d) Engaged in Fishing e) Engaged in Towing or Pushing f) Sailing Vessel under way in poor visibility
-•••	A vessel being towed
••••	A Pilot boat engaged on duty

*Bells*

Rapid ringing for 5 seconds every minute (or less)	A vessel under 100 metres in length at anchor
Rapid ringing for 5 seconds forward followed by a gong for 5 seconds aft, may be followed by • - • on a whistle	A vessel over 100 meters in length at anchor
Three strokes of a bell followed by rapid ringing of a bell for 5 seconds and then 3 strokes of the bell	A vessel under 100 metres aground.
3 strokes of a bell followed by Rapid ringing of a bell for 5 seconds followed by 5 seconds sounding of a gong followed by 3 strokes of a bell	A vessel 100 metres or more aground



**To Attract Attention:** If necessary to attract the attention of another vessel, any vessel may make light or sound signals that cannot be mistaken for any signal authorised elsewhere in these rules.

## **0908 STEERING RULES**

### **0908.1 Lookout**

Every vessel shall at all times, maintain a proper lookout by sight and hearing, as well as by all available means appropriate in the prevailing circumstances and conditions, so as to make a full appraisal of the situation and of the risk of collision.

### **0908.2 Safe Speed**

Every vessel shall at all times, proceed at a safe speed, so that she can take proper and effective action to avoid collision and can be stopped within a distance appropriate to the prevailing circumstances and conditions. In determining a safe speed the following factors shall be among those taken into account:

- By all vessels
- a) The state of visibility.
  - b) The traffic density.
  - c) The manoeuvrability of the vessel.
  - d) At night, the presence of background lights.
  - e) The state of wind, sea, current and proximity of navigational hazards.
  - f) The draught in relationship to the depth of water.

### **0908.3 Risk of Collision**

a) Every vessel shall use all available means appropriate to the prevailing circumstances and conditions, to determine if a risk of collision exists. If there is any doubt such a risk shall be deemed to exist.

b) In determining if the risk exists, the following conditions shall be among those taken into account:

1. Such risk shall be deemed to exist if the compass bearing of an approaching vessel does not appreciably change.
2. Such risk may sometimes exist, even when an appreciable bearing change is evident, particularly when approaching a large vessel or a tow or when approaching a vessel at close range.

### **0908.4 Action to avoid a Collision**

a) Any action to avoid collision shall, if the circumstances of the case permit, be positive, made in ample time and with due regard to the observance of good seamanship.

b) Any alteration of course and/or speed to avoid collision shall, if the circumstances permit, be large enough to be readily apparent to another vessel observing visually or by radar. A succession of small alterations of course and/or speed should be avoided.

**0908.5 The Giving Way Vessel (for 2 or more unhampered power driven vessels converging)**

The circle of the horizon around a ship is divided up into three arcs, which represent the arcs of visibility of the two sidelights and the stern light. These arcs are referred to as the Right of Way arc, the Giving Way arc and the overtaking arc.

- a) **Head on situation** - when two Power Driven Vessels are meeting on reciprocal or nearly reciprocal courses so as to involve Risk of Collision, each shall alter her course to starboard so that each shall pass on the Port side of the other.
- b) **The Right of Way arc** - any vessel approaching your ship within this arc must take avoiding action to prevent a risk of collision. Your ship maintains its course and speed.
- c) **The Giving Way arc** - if there is a risk of collision with any vessel approaching your ship within this arc you must take avoiding action.
- d) **The Overtaking arc** - it is the responsibility of any vessel approaching you within this arc to take avoiding action. If the vessel on overtaking moves into the Giving Way arc she must keep clear of you until she is finally past and clear ahead.

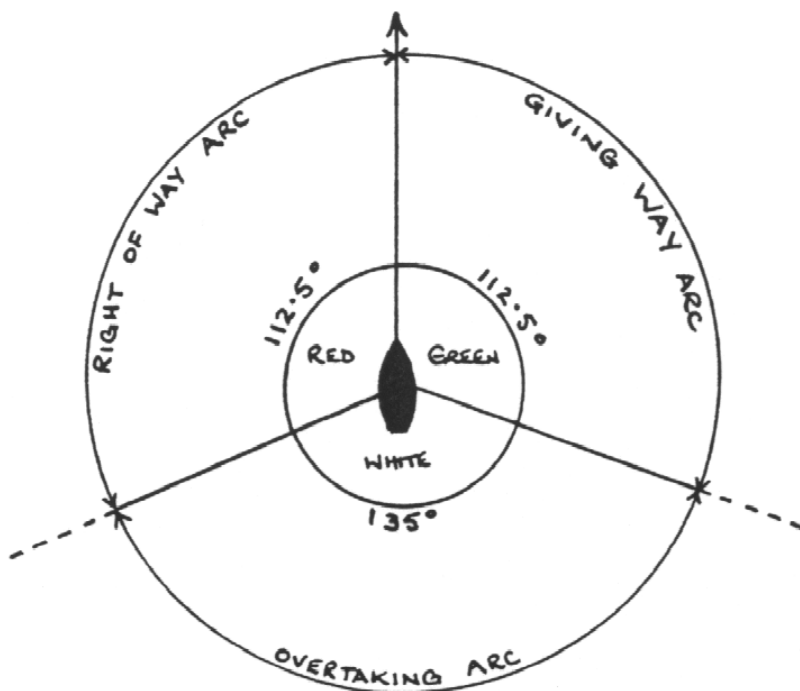

**0908.6 A Power Driven Vessel's Conduct**

When obeying the steering and sailing rules, the following rules should be borne in mind:

- a) If yours is the giving way vessel, always give the other vessel as wide a berth as circumstances allow. It is dangerous to pass close to another vessel.
- b) If yours is the giving way vessel, your avoiding action should be made in such a manner so as to leave no doubt of your intentions in the mind of the person in charge of the other vessel.

You should therefore:

1. Take avoiding action in plenty of time.
2. Make a sufficiently large initial alteration of course for your intentions to be made clear both visually and on radar.
3. Steady on your new course without undue yawing.
4. Make appropriate sound signals if you are in sight of another vessel.

c) When another vessel is approaching, steer as steady a course as possible and make allowance for the other vessel yawing. A vessel approaching nearly head on, on an opposite course may appear to be end on now and again because she is yawing. Under such circumstances, she should be treated as approaching end on and you should alter course to Starboard and give her as wide a berth as practicable.

d) In a narrow channel or fairway, keep to that side of the channel, which is on your starboard side.

## 0909 LIGHTS ON VESSELS

### 0909.1 Definitions

a) **Masthead Lights:** means a white light placed over the fore and aft centreline of the vessel showing an unbroken light over an arc of horizon of 225 degrees. It shall be fixed so as to show the light from right ahead to 22.5 degrees abaft the beam on either side of the vessel.

b) **Sidelights:** means a green light on the starboard side and a red light on the port side, showing an unbroken light over the arc of the horizon of 112.5 degrees, and so fixed to show the light from right ahead to 22.5 degrees abaft the beam on its respective side. In a vessel of less than 20 metres in length, the sidelights may be combined in one lantern carried on the fore and aft centreline of the vessel.

c) **Stern Light:** means a white light placed as near as practicable at the stern, showing an unbroken light over an arc of the horizon of 135 degrees. It shall be fixed so as to show the light 67.5 degrees from right aft on each side of the vessel.

d) **Towing Lights:** means a yellow light having the same characteristics as the 'Stern light'.

e) **All Round Light:** means a light showing an unbroken light over an arc of the horizon of 360 degrees.

f) **Flashing Light:** means a light flashing at regular intervals at a frequency of 120 flashes or more per minute.

## 0909.2 Visibility of Lights

	<i>Vessels 50 metres or more in length</i>	<i>Vessels 12 metres but less than 50 mtrs</i>		<i>Vessel less than 12 metres in length</i>
Masthead Light	6 miles	5 miles * 3		2 miles
Sidelights	3	2	2	1
Stern Lights	3	2	2	2
Towing Light	3	2	2	2
Red, white, green or yellow all round light	3	2	2	2

\* Where the length of the vessel is less than 20 metres.

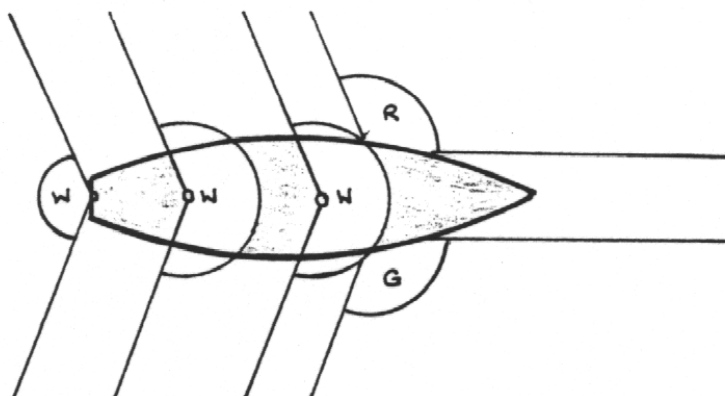

## 0910 BUOYAGE

### 0910.1 Lateral Marks

**Port Hand Buoys** are left to Port and **Starboard Hand Buoys** are left to Starboard when:

- Approaching or entering a Port or Estuary
- Going in the "General direction".

If there could be doubt the direction is marked on the chart.

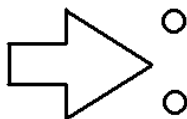

### 0910.2 Port Hand Mark

Buoy shapes  
Colour  
Top Marks  
Lights

Pillar, Spar or Can  
Red  
Can Shaped if any  
Red Flashing - any rhythm - if lit

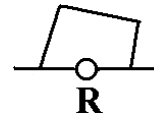
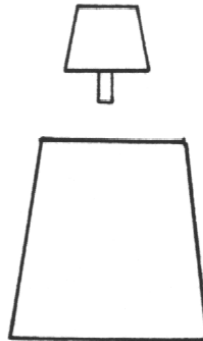
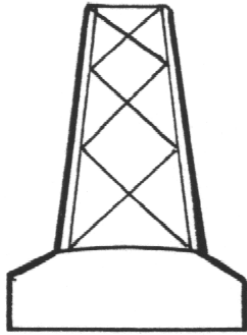

### 0910.3 Starboard Hand Mark

Buoy shapes  
Colour  
Top marks  
Lights

Pillar Conical or Spar  
Green (very occasionally Black)  
Cone Shape if any  
Green Flashing, any rhythm - if lit

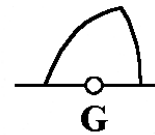
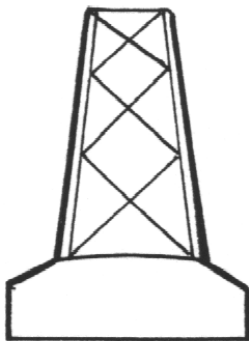

### 0910.4 Isolated Danger Marks

Buoy shapes	Pillar or Spar
Colour	Red and Black bands
Top Marks	2 Black Spheres
Lights	White Group Flashing (2) - if lit

These buoys are stationed over a danger with navigable water round it.

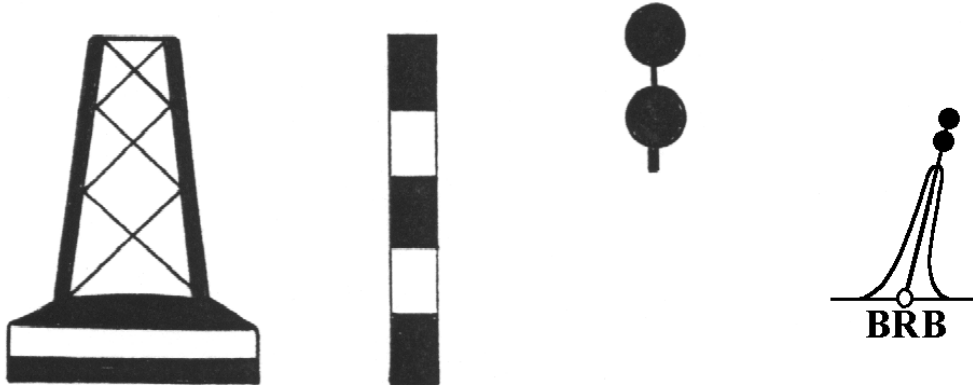

### 0910.5 Safe Water Mark

Buoy Shapes	Pillar, Spar or Spherical
Colour	Red and White Vertical Stripes
Top Marks	Red Sphere if any
Lights	White Isophase, Occulting or Long Flashes every 10 seconds - if lit

Used to mark Mid Channel or Landfall

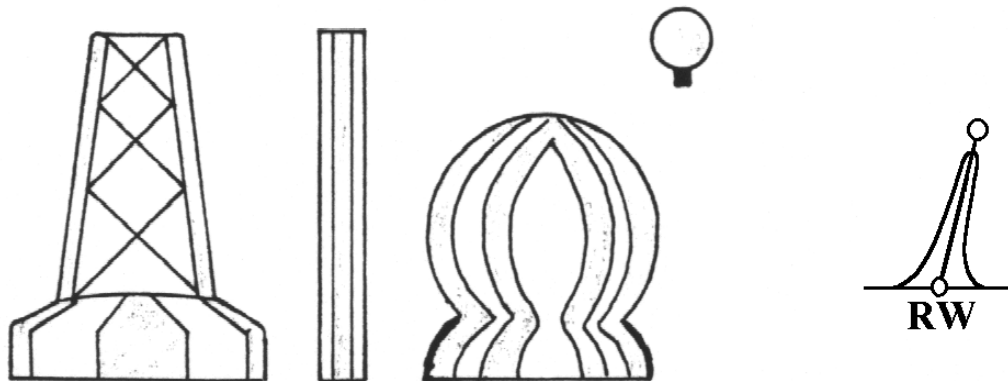

### 0910.6 Special Marks

Buoy shapes	Pillar, Spar, Barrel, Conical, Spherical or Can shaped
Colour	Yellow
Top Marks	A Yellow Cross if any

Lights  
lights

Yellow if any and may have a rhythm not used by white

These buoys are not primarily to assist in navigation, but to indicate special features. If Can, Spherical or Conical shapes are used they will indicate the side on which the buoy should be passed.

**Uses of Special Marks**

- a) Ocean Data Acquisition Systems: ODAS for short - buoys carrying oceanographic or meteorology sensors
- b) Traffic Separation marks: Where the use of conventional channel markings might cause confusion.
- c) Spoil ground marks
- d) Military Exercise Zone marks
- e) Cable or Pipeline marks including outfall pipes
- f) Recreation Zone marks
- g) To define a channel within a channel

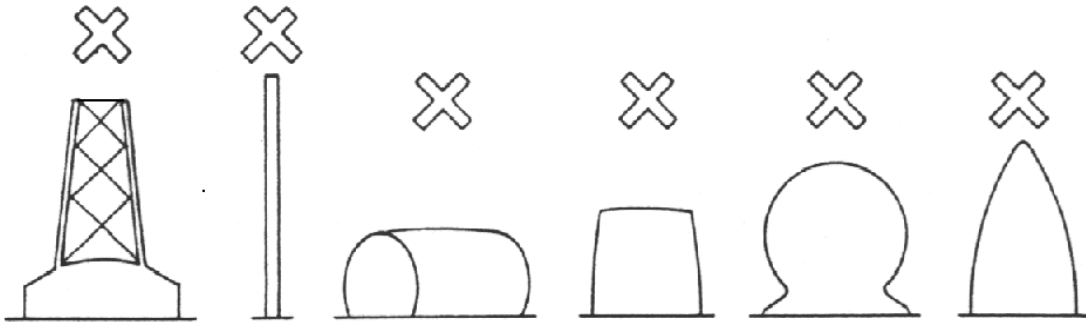

**0910.7 Cardinal Marks**

Buoy Shapes  
Colours  
Top Marks  
by day.  
Lights

Pillar or Spar  
Black and Yellow  
Black double cones - These are the most important features  
White in colour.

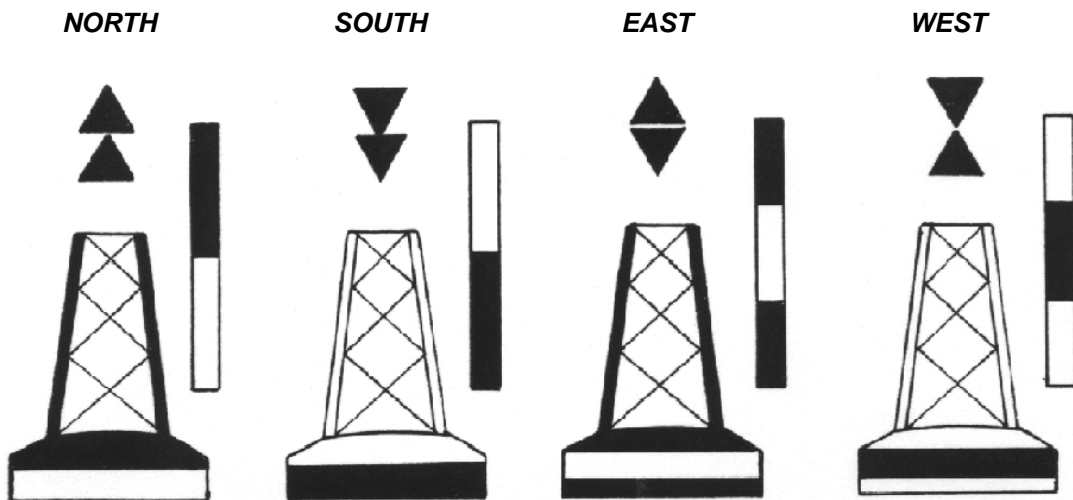

**Lights if lit**

Continuous  
Flashing (9)

Group Flashing (6)  
+ 1 Long Flash

Group Flashing (3)

Group Flashing

You pass North of a Northerly Buoy and South of a Southerly Buoy etc.  
Cardinal marks can be used to mark hazards and dangers and they indicate the navigable water to the named side of the mark.  
All cardinal marks are either pillar or spar buoys – cone and can buoys are not used.

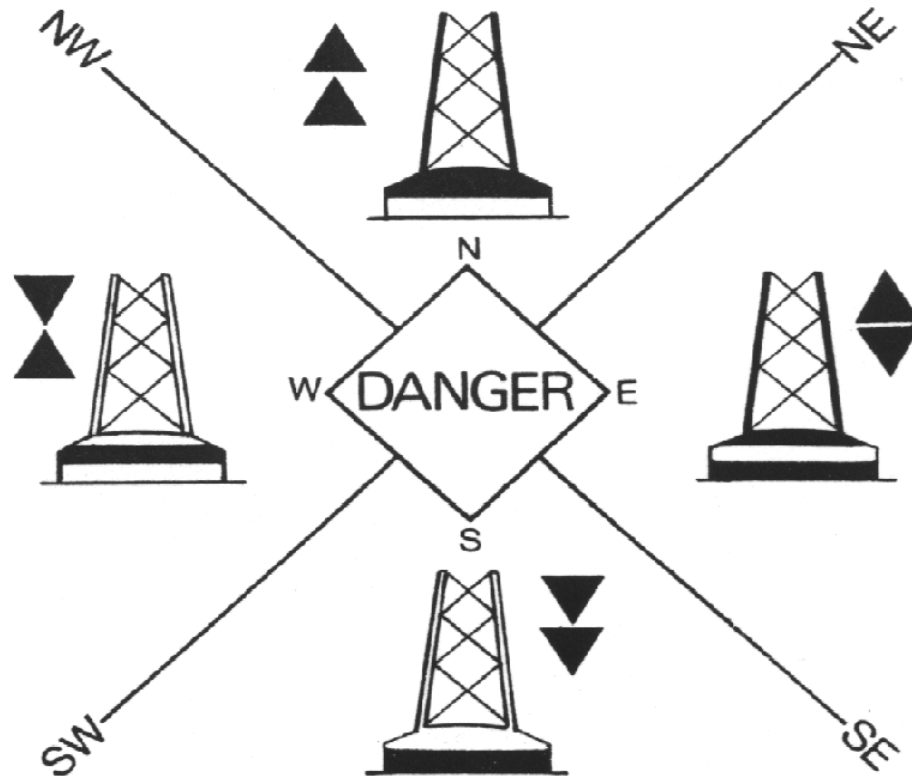



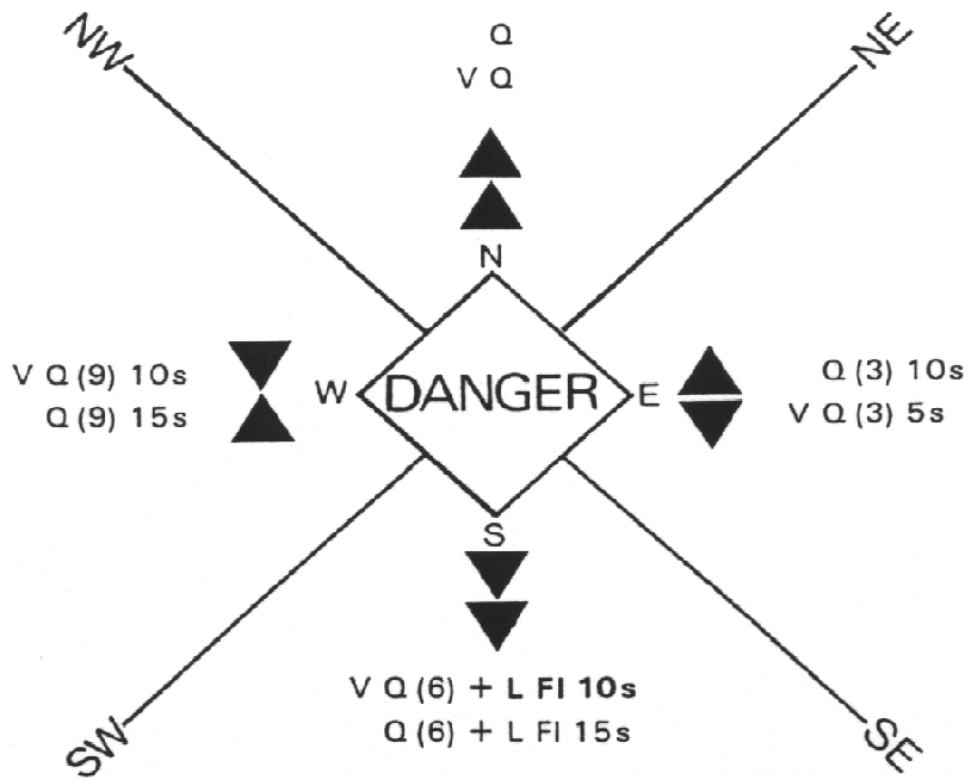

## 0911 SAFETY AND DISTRESS

### 0911.1 Distress Signals

The following signals, used or exhibited either together or separately, indicate distress and need of assistance:

- a) A Gun or other explosive signal fired at intervals of about one minute.
- b) A continuous sounding with any fog-signalling apparatus.
- c) Rockets or shells, throwing Red Stars one at a time at short intervals.
- d) S.O.S by light or sound.
- e) The spoken word "MAYDAY".
- f) International code signal of distress, flags November Charlie.
- g) A square flag with above or below it, a ball or anything resembling a ball.
- h) Flames on a vessel (as from a burning tar barrel or oil barrel etc).
- i) Rocket parachute or hand flare showing a Red light.
- j) Orange Smoke.
- k) Slowly and repeatedly raising and lowering of outstretched arms to each side.
- l) Signals transmitted by emergency position-indicating radio beacons.
- m) A piece of Orange canvas with either a Black Square or Circle.
- o) A dye marker.
- p) A diver on the surface - clenched fist arm wave, bending at the elbow.

REMEMBER THAT THE LACK OF A SIGNAL COULD ALSO MEAN DISTRESS.

## CHAPTER 10

# ELECTRONIC NAVIGATION

**THIS CHAPTER COVERS THE NEW ADDITIONAL ITEM OF ELECTRONIC NAVIGATION AND CONSISTS OF THREE PARTS:**

**1001 ELECTRONIC CHARTS**

**1002 SATELLITE NAVIGATION**

**1003 RADAR**

**Author: Lt Cdr (SCC) K. G. Booth AFRIN RNR ASO (Sea) NW**

**Suggestions for additional items or improvements are welcomed and should be submitted to the Author either by post or e-mail.**

**(e-mail: ken\_booth @rnli.org.uk)**

**30.07.2005**

**Reading/Video/CD ROM list:**

**E Charts:**

**CD – RYA Chart Plotter (£21.00 in 2005)**

**GPS:**

**Book – “GPS Afloat” by Bill Anderson. Pub: Fernhurst. (£14.95 in 2005)**

**Radar:**

**Video – “Radar” by Amberley Marine. (29.50 in 2005)**

**CD – “Radar Trainer” by Lightmaster Softwear. (£ nk)**

**Book – “An Introduction to Radar” by the RYA (£nk)**

### **1001 ELECTRONIC CHARTS**

#### **1001.1 General**

There are both Official Government and Commercially produced electronic charts. There are however only two basic types – Raster and Vector – depending on the electronic make up of the charts produced.

#### **1001.2 Raster data Charts**

These are pure electronic reproductions of the paper charts.

They are not intelligent i.e. you cannot ask questions about chart features using the chart plotting systems electronic cursor. What you see is what you get – just like a paper chart.

The British Admiralty (BA) electronic charts fall into this category. The BA system is called ARCS – Admiralty Raster Chart Service.

### 1001.3 Vector data Charts

These charts owe much too modern computer technology.

They are intelligent – you can ask questions and get information extra to that given on the chart - such as for a Coastal Light. By using the chart plotting systems electronic cursor you can find details of the structure e.g. white concrete tower. This is information useful in passage planning (see Passage Planning section) and would otherwise have to be obtained from Admiralty Lights Lists (ALL) or Nautical Almanacs.

Drawing lines e.g. marking off 'No go areas' (see Passage Planning section) on the chart is easily achieved. It is very similar to drawing on your PC.

All Electronic charts allow you to draw courses on them – just like a paper chart. The lines – usually referred to as a 'route' - are drawn using an electronic cursor. The places where you will alter course are called waypoints.

### 1001.4 The Electronic Chart

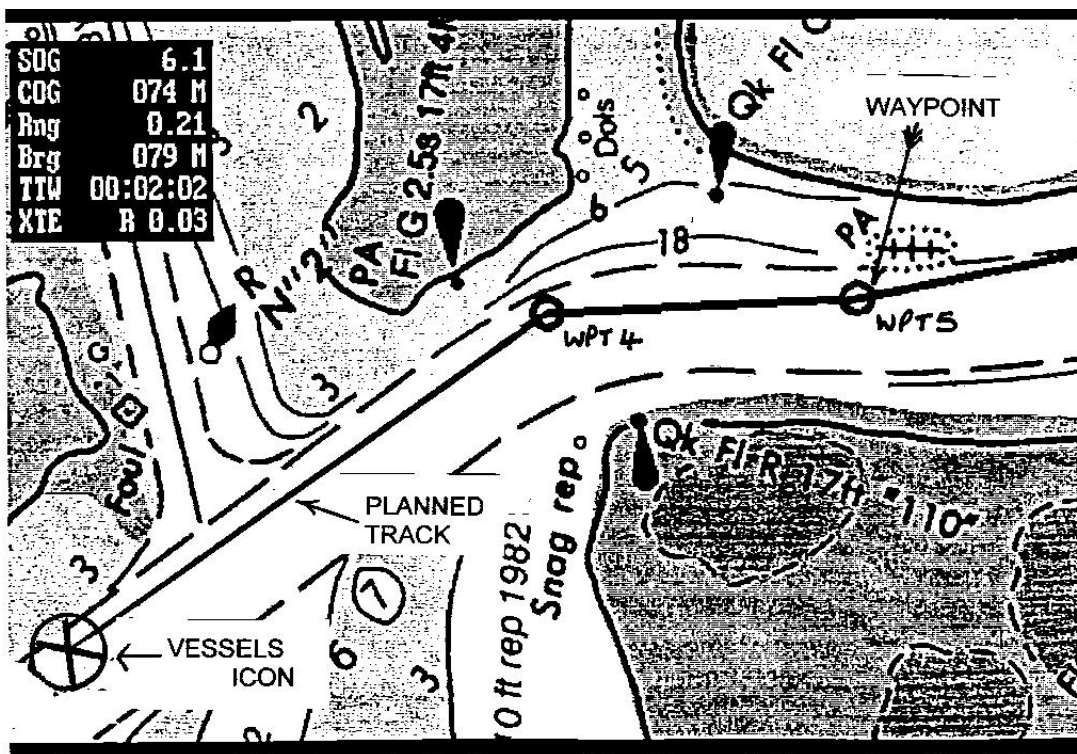

Example of an Electronic chart – showing a route and waypoints

This route and its waypoints, once checked for navigational safety, can be down loaded into a GPS (see section 2) and used to navigate a vessel. When underway and following a route a moving icon represents the vessels position.

Some chart plotting systems will allow the plotting of ranges and bearings to fix a position.

There are both simple and complex systems available. For example you can have combined chart plotting/GPS systems. It is possible to overlay an electronic chart with the picture from radar. In the today's marine electronics industry the world truly is your oyster.

## **1002 SATELLITE NAVIGATION (GPS)**

### **1002.1 Navstar GPS**

GPS or to give it its full title "NAVSTAR Global Positioning System" is a satellite navigation system owned and operated by the United States Department of Defence. It is freely available to all mariners.

The system consists of 24 satellites, about 11,000 miles above the Earth, evenly spaced between 6 orbital planes.

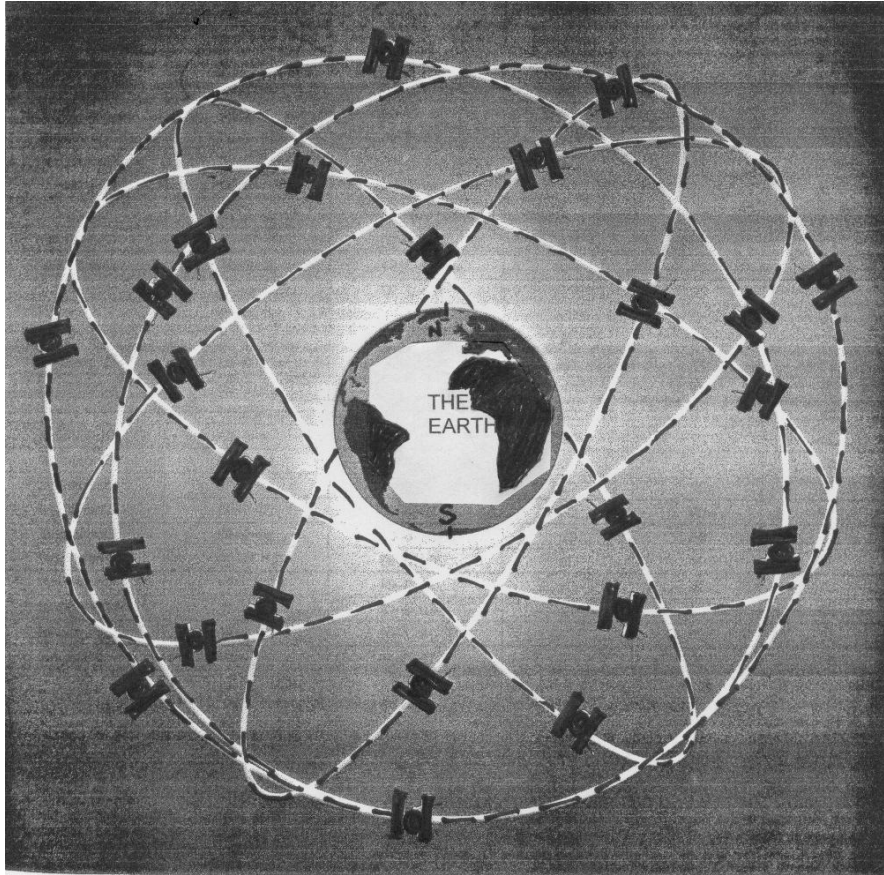

GPS: Satellites

### **1002.2 Other systems**

"GLONASS" is a similar Russian operated system.

"GALILEO" is a European system presently (2005) under development.

### **1002.3 How GPS gives a position**

Four satellites (with a good angle of cut) are required to give a good fix or position. Your GPS set will (in normal circumstances) have up to 12 satellites available at any one time. It will select the satellites that give the best angle of cut for a good fix.

The system works by the satellite making a transmission that is received by the observing vessels aerial/set. The time taken by the signal from transmission to reception is used to produce a radius. Thus it places the vessel somewhere on the circumference of a circle, the centre of which is the satellite. We are interested in the part of this circle that touches the Earth's surface.

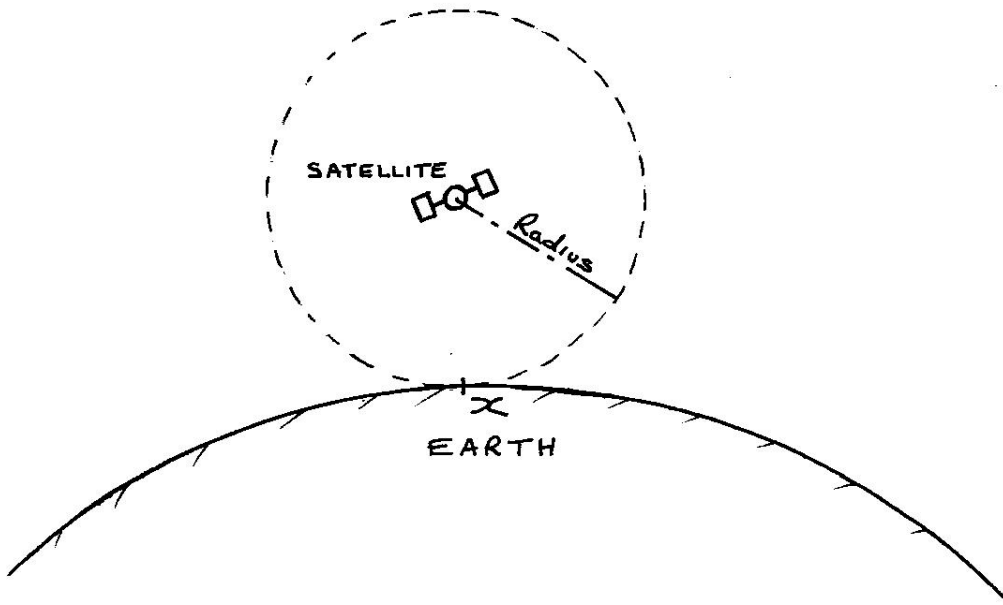

GPS: Single position line

The other satellites selected by the set will each produce a position line. The point where these position lines all cross on the Earth's surface gives our position. This is converted to Latitude and Longitude (LAT & LON) by the GPS set.

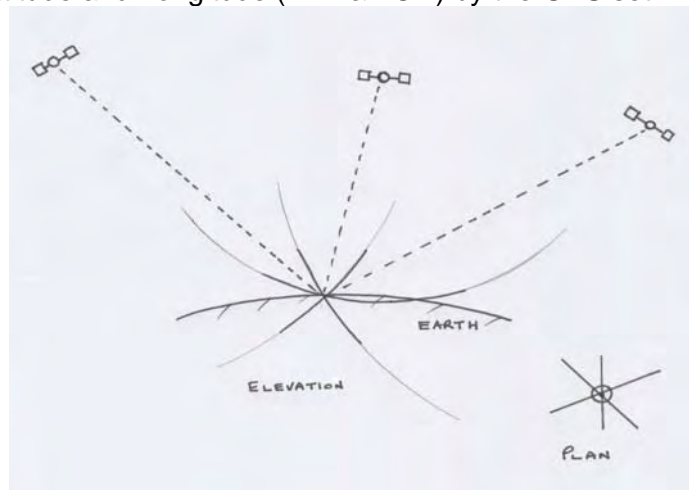

GPS: Position lines and fix

<b>POSITION</b>	<b>WGS 84 Datum</b>		
<b>N</b>	<b>52° 37'.068</b>		
<b>W</b>	<b>009° 22'.123</b>		
<b>COG</b>	<b>180°</b>	<b>SOG</b>	<b>25 Kn</b>

GPS: The set – A positional screen

The system has an accuracy of +/- 10metres on your actual position. The position can be made even more accurate by the use of Differential GPS (DGPS).

**1002.4 A GPS Set**

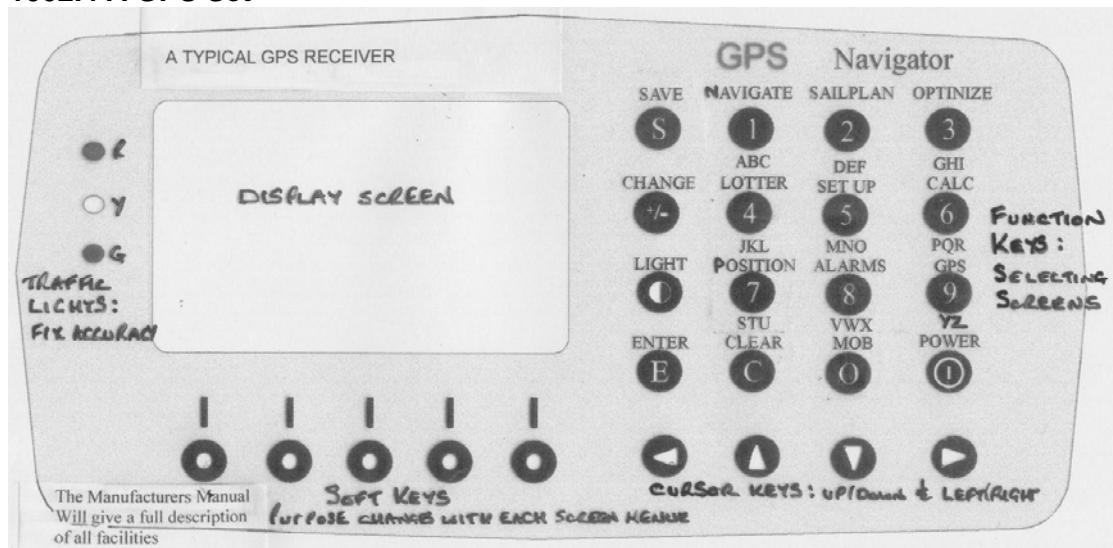

A typical GPS Receiver (By kind permission of RNLI)

**1002.5 Differential GPS (DGPS)**

There are various forms of DGPS – we will look at the coastal system. DGPS is a land based radio system that sharpens up the accuracy of GPS in coastal waters. The use of DGPS produces an accuracy of +/-5metres.

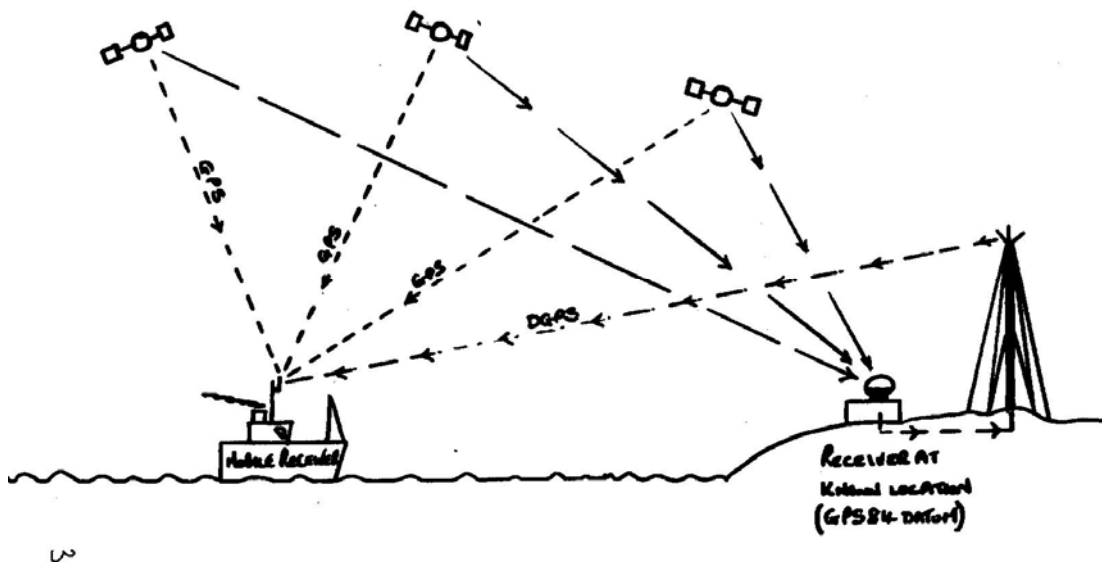

### DGPS: The system

Essentially the land based Reference Station (RS) knows exactly where it is by the datum used by the GPS system – WGS84 - World Geodetic Survey 1984.

This is the same datum that is used for all current (i.e. say from 2004) British Isles Admiralty paper charts.

The observed differences between the actual position of the RS and its position as given by an individual satellite are broadcast by a radio signal to vessels fitted for DGPS. This produces a more accurate position.

### 1002.6 The navigational use of GPS

Apart from giving a constant Lat & Lon position of your vessel the GPS can be used for Navigating.

Many vessels use electronic charts in conjunction with GPS. This aspect is discussed under section 1 - Electronic Charts.

Without Electronic chart plotting systems your planned route on a paper chart can be input manually to the GPS. Each course alteration point becomes a Waypoint (Wpt). You work out the Lat & Lon of each waypoint in turn and input them to the GPS

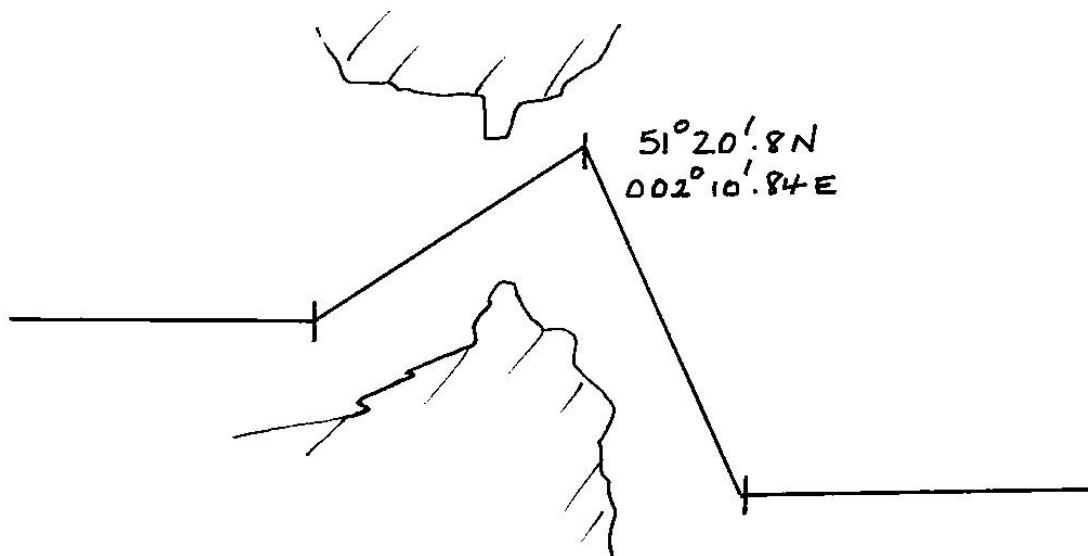

Waypoints: the paper chart – working out Lat & Lon

The GPS will produce navigational information such as:

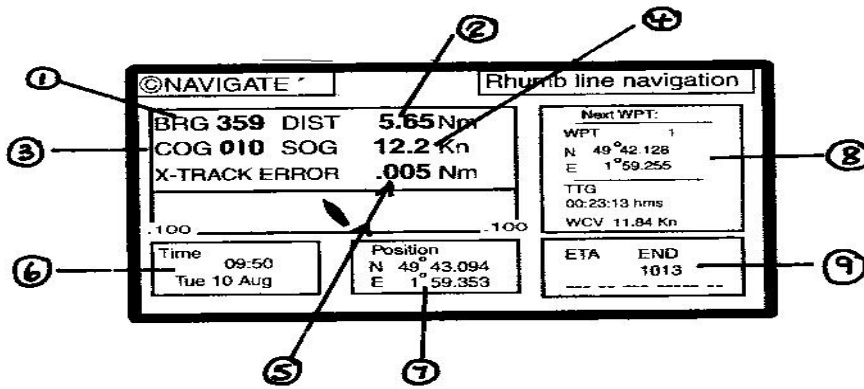

GPS: The Set – Navigational information

- 1: The course to steer to the waypoint – this will allow for TS&D
- 2: Distance to run – to waypoint
- 3: Course made good – over the ground
- 4: Speed made good – over the ground
- 5: Cross track error – how much and to what side you are off course/track
- 6: Local time – BST or UTC
- 7: Vessels current position
- 8: Details of the waypoint you are approaching:
  - a. The number in your route/passage plan (see section 4 for Passage Planning)
  - b. Its Lat & Lon and c. TTG – Time to go to the waypoint
- 9: An Estimated Time of Arrival (ETA) at the last waypoint in your loaded route

## 1003 RADAR

### 1003.1 A Radar set



A typical radar set (By kind permission of RNLI)



### 1003.2 General

**Radar** stands for:

Radio  
Aid  
For determining  
Direction  
And  
Range

Radar can be used both as an aid to collision avoidance and an aid to navigation. It is the navigational aspects of radar we will discuss here.

### 1003.3 The Echo Principle

Radar works by transmitting a pulse of radio energy and receiving some of that energy (the echo) back. Energy is reflected back when it hits an object (target) such as land, a vessel or navigational mark etc. This returning echo from the target paints in a picture on the radar screen

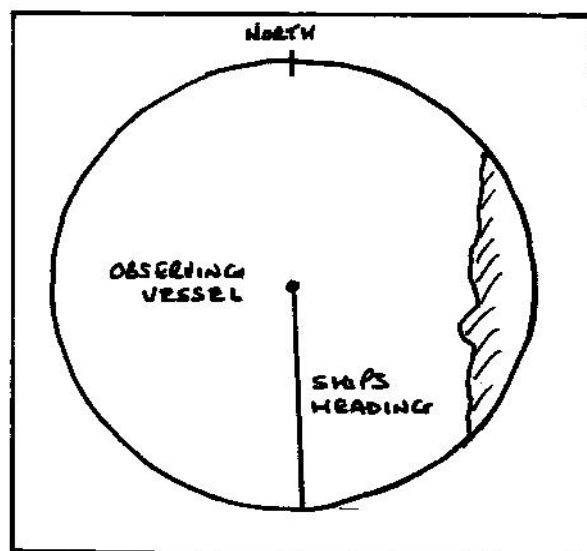
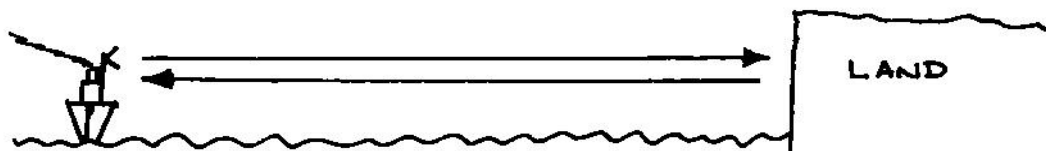

Radar: The Echo Principle

### 1003.4 Components of the Radar Set (By kind permission of RNLI)

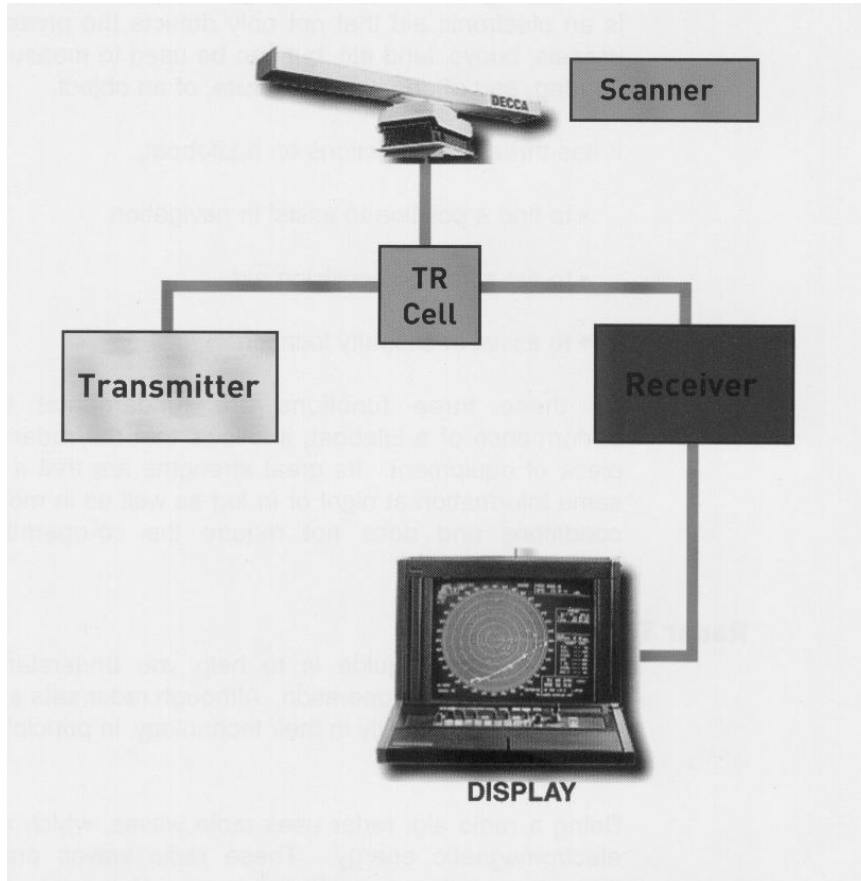

The Transmitter produces correctly formed pulses of energy.

This pulse of energy goes via the T/R Cell (Transmit/Receive) to the Scanner. The Scanner is also known as the Aerial or Antenna.

As soon as the scanner has transmitted the pulse, the T/R cell switches from Transmit to Receive.

A scanner spends 99.5% of its time listening for returning echoes.

The Receiver receives then amplifies the returning echoes and sends them to the Display. The Display is the radar screen itself.

### 1003.5 Radar Horizon

As we have seen the scanner transmits a pulse of energy. The path of the pulse may be considered 'line of sight'. The higher the scanner the further the radar can see. You will note that the pulse/beam bends slightly over the horizon – thus it is sometimes possible to detect a target that may be below your visible horizon.

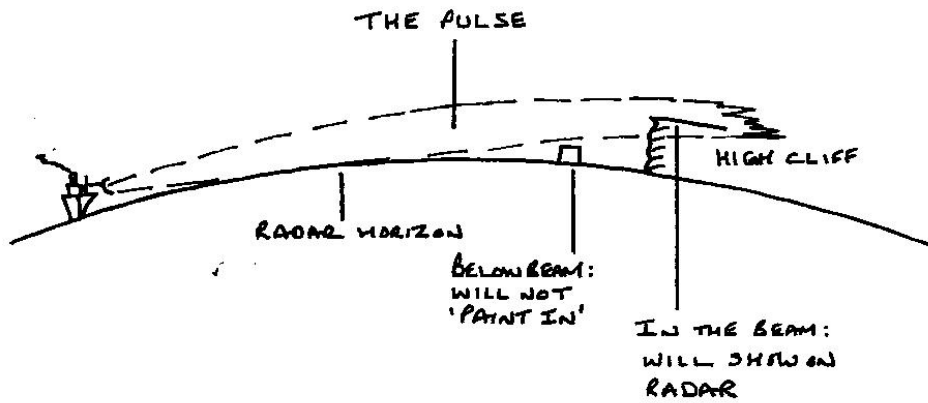

Radar Horizon & Beam

The radar beam has a vertical and horizontal component:

**1003.6 Vertical Beamwidth (VBW)**

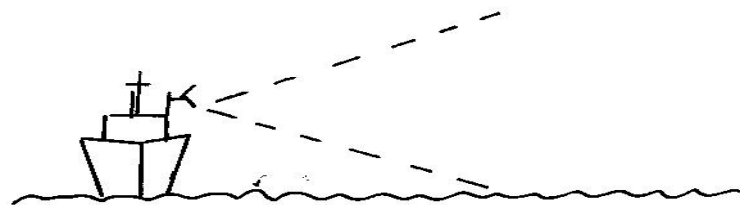

Vertical Beamwidth – typically 20° to 30°

This ensures that at least some part of the beam is horizontal even when the vessel pitches and rolls.

**1003.7 Horizontal Beamwidth (HBW)**

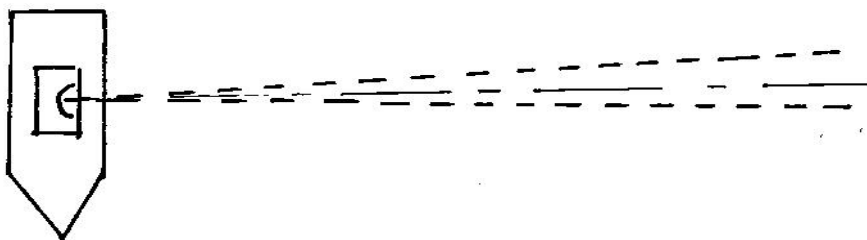

HBW – much smaller between 2° and 5°

**1003.8 Radar Bearings**

As all the energy is concentrated in one narrow direction at a time the radar is able to measure a bearing along the axis of the beam. The narrower the Beam the better the accuracy.

# CHAPTER 11

## PASSAGE PLANNING

Suggestions for alterations, improvements and additional material are welcome.

These should be sent via post or e-mail to the author:

[Ken\\_booth@rnli.com.org](mailto:Ken_booth@rnli.com.org)

Lt Cdr (SCC) K. G. Booth AFRIN RNR  
ASO (Sea) NW  
26.09.2005

### Reading/Video/CD ROM list

**Book/Charts – RYA Practice Navigation Tables and 2 Charts (8.75 in 2005)**

**Book – HMSO “Admiralty Manual of Navigation Vol 1” 1987Ed**

**MCA – Latest ‘MSN’ on Passage Planning**

## **1100 PASSAGE PLANNING**

### **1101 Preamble**

These notes are written with the intention of assisting Chartwork Instructors who may have no practical experience of the art of Passage Planning.

Passage Planning is included in the Cadet Chartwork syllabus for several reasons:

- To provide a logical conclusion to a Cadet/Adults Chartwork Training.
- To demonstrate the practical application of what has been taught and learnt.
- To encourage cadets to go to sea with the Corps and apply their newly acquired skills.
- To encourage interest and further study in the noble art of Chartwork/Navigation e.g. through the Royal Yachting Associations (RYA) Dayskipper courses.

### **1101a The Task**

1. Cadets are to plan a short daylight passage of between ? and ? miles.
2. The vessel used when setting the task is to be under 25 metres LOA. The Instructor is to set realistic draught and maximum speed.
3. The location of the passage along with its departure and arrival ports will depend on the materials available to the Instructor.

∇ Training suggestion:

Use the RYA charts and the associated Practice Navigation Tables (PNT). The PNT holds all the information required for a passage on those charts. The RYA charts are specially prepared British Admiralty (BA) training charts.

4. The task can be completed individually or as a group activity.

∇ Training suggestion:

Where possible split the group into teams of two cadets. The Instructor leads and demonstrates the skill and the Cadets apply the techniques.

∇ Training suggestion:

Once planned make it a 'virtual voyage'.

When the Instructor has approved the plan, exact dates, departure time etc can be given to the teams. With a little ingenuity the Instructor can (when the plan is presented for approval) plan in fixing information; put in Collision Regulation (Coll Regs) and safety situations; request ETA's etc etc.

This technique makes it doubly interesting and enjoyable – the next best thing to actually going to sea! – and has been used very successfully by the author when teaching Adult RYA courses.

The plan will form the basis of the Class I assessment.

### **1101B Assessment of Cadets**

The plan (charts and notebook) will form the basis of the Class I assessments. The assessor can ask questions and require demonstration of practical competence based around the passage.

### **1102 Introduction to Passage Planning**

Navigational passages must be carefully planned "Everyone is liable to make mistakes; over three quarters of all groundings are attributable to human error of some kind" (Admiralty Manual of Navigation). A sound passage plan may not prevent a grounding but it does reduce the chances of making mistakes.

In the notes the term 'Master' refers to the person in charge of the vessel. It is assumed that the vessel is less than 25 metres LOA as larger vessels have additional items to consider. All guidance refers equally to motor and sailing vessels.

Voyages (berth to berth) regardless of length can be split into two major parts:

- PREPARATION – This includes:
  - APPRAISAL (gathering information)
  - PLANNING (preparation of the detailed plan)
- EXECUTION – This includes:
  - ORGANISATION (tactics for execution of the passage)
  - MONITORING (of progress)

We will now explore each section in detail.

### **1103 The Plan: Preparation - Appraisal**

The risks of any voyage need to be assessed - Appraisal is the process of examining these risks. It is at this stage that all relevant information is gathered and a good foundation for the plan is laid.

#### INFORMATION SOURCES:

- BA Chart Catalogue  
NP109 – Covers North West Europe inc the British Isles. This publication is issued annually and is available gratis from Admiralty Chart Agents and most Chandlers.
- Navigational charts  
In the Corps we use BA charts. Commercial charts (e.g. IMRAY) are also available.
- Notice to Mariners (NTM)  
This is the publication – issued weekly – that contains chart corrections and updates/corrects BA publications. Charts should, of course, be up to date when used.
- Reeds Nautical Almanac  
Published yearly it contains all the information necessary for small vessel passage planning.

If using BA publications you require several publications. These include:

- Pilot books (NP various)  
These contain detailed passage/pilotage information.
- Admiralty Tide Tables (ATT) (Vol 1 NP201 )
- Admiralty List of Lights (ALL) Vol A NP74 )
- Admiralty List of Radio Signals (ALRS)  
Vol 6 lists Port and information services etc.
- Admiralty Tidal Stream Atlases (NP various)  
There are several books required to cover the British Isles.
- Mariners Handbook (NP100)  
A BA publication containing items of general interest.
- Electronic Navigation systems handbooks  
Operator's guides to the navigational systems fitted on the vessel.
- Weather information  
Obtaining the latest information covering the dates of the passage.

Full weather information is obtainable from a very wide variety of sources. These range from the traditional radio broadcasts via facsimile reception to the downloading of satellite images.

The timings for reception of weather information should be researched and noted.

- Vessels characteristics
  - Deepest draught – required for tidal calculations.
  - Air draught (maximum height) – to check overhead clearances such as bridges.
  - Length overall (LOA) – tip to toe fore and aft measurement.
  - Beam (maximum width) – required if entering marinas/locks etc.
- Personal experience

Has someone on the Crew been there before? If so their experience may be of use.

When the information is collected together the Master, in consultation with his officers, will make an overall appraisal of the passage

The main consideration at this stage will be to determine the distance tracks should be laid off coastlines and dangers.

The distances off any particular point will be determined by such factors as the vessels draught relevant to the availability of safe water etc.

Once the Master has made his appraisal he will delegate one of his Officers to plan the voyage. It is however the Master who carries the final responsibility for the plan.

#### **1104 The Plan : Preparation - Planning**

See Appendix 1

- Charts

Collect together all of the charts for the intended voyage. Place and number them in passage order. Check that charts are corrected to the latest NTM. Charts adjacent to the passage area or those for diversion ports should be included.
- No-go areas

Outline and crosshatch areas on the route where the vessel should not go. Be careful not to obscure important detail such as a navigational mark. In confined waters no-go areas will vary according to the time of passage – taking into account the height of tide. Areas less than your vessels draught (plus safety margin) will be considered no-go.
- Distances off

This will have been decided during the ‘broad brush strokes’ process of appraisal. This together with no-go areas will shape up the limits/areas available for the passage.
- Planned track

The decisions made (distances off and no-go areas) enable the track to be drawn from port to port on small-scale charts. This is the passage overview.

These tracks will enable distances and steaming/journey times to be obtained. When departure time is known the estimated times of arrival (ETA) at various points can be calculated.

The tracks are now transferred (with great care) to larger scale charts for navigational purposes. You always use the largest scale chart available.

The following can be marked on your track:

- Distances to run – a countdown mileage to the destination.
- The true (T°) direction of the track i.e. the course to be made good.
- Changes of chart – points where you transfer to another chart.
- Identifiable features.
- Tide, set and drift (TS&D). This information can be adjusted as required.

At this stage the Latitude and Longitude (LAT & LON) of course alteration points (etc) can be input to the Global Positioning System (GPS) navigator if fitted.

- Selection of objects for fixing  
If the vessel is fitted with radar – radar conspicuous targets and RACONS should be identified.  
  
Select leading marks, transits and conspicuous objects that can be used to fix your vessel.
- Tidal information  
Calculate tidal heights, times and ranges. Mark up tidal graphs as required. Check to ensure you have enough water for your purposes. Remember to allow a realistic under keel clearance.
- Radio  
Channels/times etc of Port radio services should be noted in the plan.
- Alternative strategy  
Have your 'bolt holes' planned – alternative ports or an anchorage – just case you run into problems e.g. bad weather, mechanical failure etc etc.  
You should also consider the possibilities of a port approach in bad visibility or at night i.e. if conditions deteriorate or you are running late!  
It is also a good idea to have a waiting area – off a port – in mind in case you have to wait to gain entry.
- Navigators notebook – see Appendix 2  
Write up the complete berth to berth plan including port (etc) sketches.
  - Port sketches – these are used to assist with port entry. You put in them the information you require.
- Completion  
On completion the plan must be submitted to the Master for approval.

### 1105 The Plan: Execution - Organisation

- Tactics  
The methods used to carry out the plan and to make the best uses of resources. Final details of the plan can be confirmed when the actual timing of the passage is known  
This will include such areas as:
  - Up dating TS&D for actual departure.
  - ETA's for tide – expected ETA's to take advantage of the tide.
  - Always bear in mind that safe execution of the passage may only be achieved by modifying the plan.
- Crew briefing  
ALL concerned should be given details of the passage and their duties.
- Voyage/Bridge preparation



Checklists are most useful to ensure you have all necessary kit/documentation etc aboard.

Check lists can cover whatever you want. Appendix 3 gives an example for a small yacht. For our purposes it would include basic Chartwork kit like 2B pencils, parallel rules, dividers etc, etc. Also to be included - the testing of Electronic navigation equipment.

### **1106 The Plan: Execution – Monitoring of Progress**

Monitoring is ensuring that the vessel follows the passage plan.

It consists of following a series of actions, checking the results and taking action.

- Fixing – knowing your position and responsibilities.
  - The first requirement of monitoring is establishing the vessels position. This can be done in several ways:
    - A 3 bearing fix.
    - With radar
    - GPSRemember electronic equipment such as radar and GPS are aids to navigation not a single means of same.
  - Fixing should be accurate and regular. The frequency will depend on your circumstances e.g. more frequent in confined waters.
  - Each time the vessel is fixed an estimated position (EP) of the next fix is worked up. Should the next fix not coincide with the EP immediate action to check the reason(s) must be taken. GPS sets will give – cross track error – i.e. the side and distance you are off track.
  
- Soundings  
Should be observed by using the echo sounder in pilotage waters.
  
- Rule of the Road – IRPCS/Coll Reg situations  
On or off track you must still observe IRPCS requirements – nothing exempts you or your vessel from conforming to the rules.
  
- Debrief  
As we briefed the Crew at the start so should we discuss the passage after its completion. Any problems areas can be highlighted and lessons learned actioned in future passages.

### **1107 Authors note:**

Although this all seems an immense amount of work the reality is that you put into the plan the items you yourself require to plan a safe passage.

Also with practice and experience the time taken is much shorter than may appear after reading this tome!

### **1108 APPENDICES:**

APPENDIX 1: Planning symbols

APPENDIX 2: The Navigators Note Book

This contains samples of an actual Passage Plan from Dover to Boulogne plus Port Plans for Boulogne and Douglas in the Isle of Man.

APPENDIX 3: A sample check list for a small yacht

APPENDIX 1

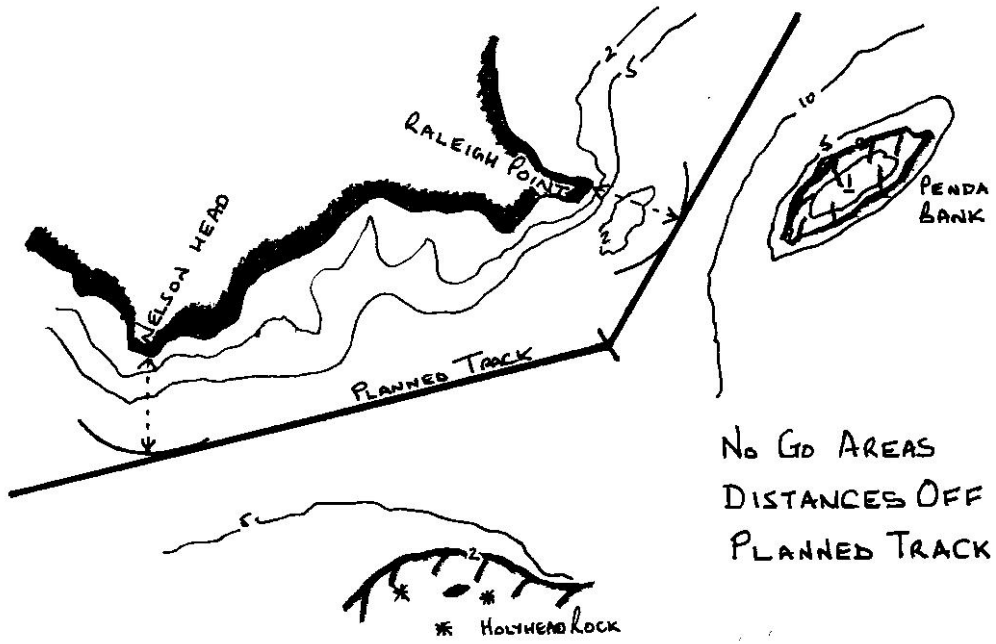

NO GO AREAS  
DISTANCES OFF  
PLANNED TRACK

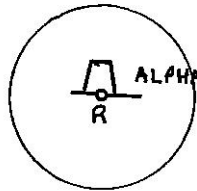

IDENTIFIABLE  
FEATURES

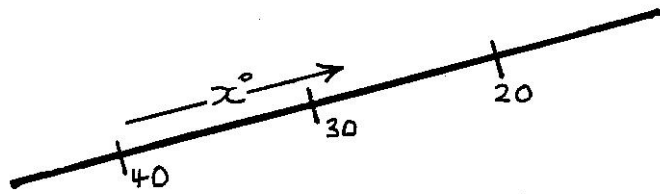

COUNTDOWN - DISTANCE  
TO RUN

090°(T) (095°M) →

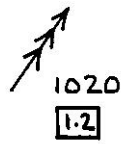

COURSE TO STEER

TS&D TIME & RATE

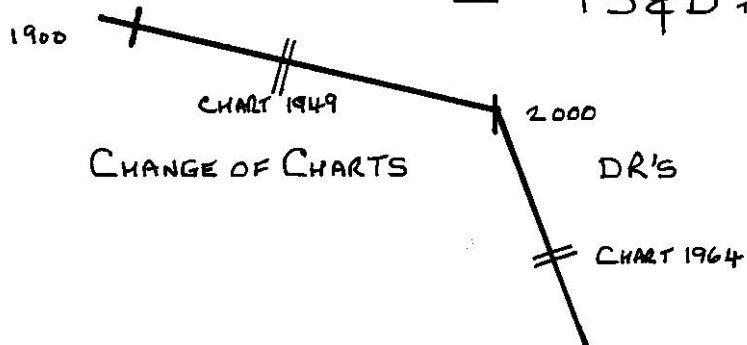

APPENDIX 2

C <sub>o</sub>	TS#D	Co To S <sub>ign</sub>	V <sup>o</sup> D <sup>o</sup>	T <sup>o</sup>	Dist SP	ETA	PASSAGE PLAN
							<p>PASSAGE PLAN DOVER W ENTRANCE TO BOULOGNE 1 OF 3            ETD DOVER WESTERN ENTRANCE: 0800A HW-4M            CLEAR AWAY READY FOR IMMEDIATE USE.            VHF CONTACT "DOVER PORT CONTROL" CH 74 CH 12            REQUEST PERMISSION TO SLIP &amp; PROCEED VIA WESTERN ENT.            INTERSS CHECK AD FOR EXT SIGNALS            RAONE OPERATIONAL &amp; MANUED END OPERATIONAL            VENTOS OPERATIONAL &amp; MANUED TO            CUMATS 1698 (DOVER) 1892 (DUSM) 438 (BOULOGNE)            MET FOR EXERCISE DEEMED SUITABLE FOR INTENDED PASSAGE.            PUBLICATIONS: ATT 61 AALS 61 6            TSA DOVER SIGNS ALL VLA INTR FOR SIGS            MARINERS HANDBOOK CHART 5011 HNCAT            NTMS &amp; ANNUAL SUMMARY.</p>
ENTRANCE 130°(r)	0.2 ASLEN 2.3 236°	TMD 121°(r)			4:315	0817 WPT 1	<p>CLEAR K0.05 OTHER SIDE WARE TSD 2.7ka 230° T ENTRANCE            DEVIATION CK 0 DOVER CG WARE T TRAFFIC            \$ RADIO MASTS 357°(r) 000 M SECURE            LEAL 0 AND MINS (82) HOOGHAN MONITOR CNIS CH 11            WARE T S S MAINTAIN TRACK AT 6 TO TRAFFIC.            ID VARE LAMBY RACON (T) FIX R # BEG OF VARE LBY            TS # D IN TSS: 236° 2.3 ka            WARE WPT 2 CHECK ACTUAL POINT OF LEAVING T.S.S            ID BUOYAGE CONTROL FEATURES &amp; KNOW CONSOLE ITEMS.            AS MARKED ON CHART            FIX 6 T AVAILABLE MEANS WARE DEPTHS LESS THAN 20M</p>
136°(r) WPT 1	SEE NOTES RE T.S.S	136°(r)			10:415	0902 WPT 2 Δ	

2003

C <sub>0</sub>	TS # D	C <sub>0</sub> T <sub>0</sub> V <sub>0</sub> D <sub>0</sub> C <sub>0</sub>	Dir Sp	ETA
209°(T) WPT 2	2-4 ASTERAN	209(T)	4-4 15	0917 WPT 3 50'41" EN 01'30" RE
185°(T) WPT 3	202(T) 2-7 208(T) 10-9	183(T)	6-7 15	0941 WPT 4 50'44" EN 01'29" RE
100°(T) WPT 4	025(T) 108	097(T)	1-8 10	0946A 1006B WPT 5
ENTRANCE T.H.O	SEE HARBOUR PLAN			

**ID** Iso Danger Mk. ZCZ By Radar Consac: Caprais-Nez.  
**FIX** RANGE RANGE & BANK OR RADAR RANGES.  
**SWAKES** NOTE START OF FERRY CHANNEL.  
**SWAKES** START OF FISHERY TRAFFIC ZONE.

**ID** Boulogne: COLUMN GRANDEANIE CATH DOME  
 1NM FROM WPT 4 **VHF** (ALL CONTROL TOWER BOULOGNE GRET CHIZ  
 ETA ENT ——— **SWAKES** TIME ZONE B (BST) A + 1HR.  
 ↘ CLEARED AWAY

**WPT 4** **SWAKES** REDUCE TO 10KN.

**WPT 5** POINT OF NO RETURN 1NM TO G TO ENTRANCE.  
**CONSIDER ACTION** GO AHEAD INCREASE IF REQD.  
**ENTRANCE** 1 CABLE TO GO **SWAKES** REDUCE TO 5KN  
**CHECK** SOUNDINGS

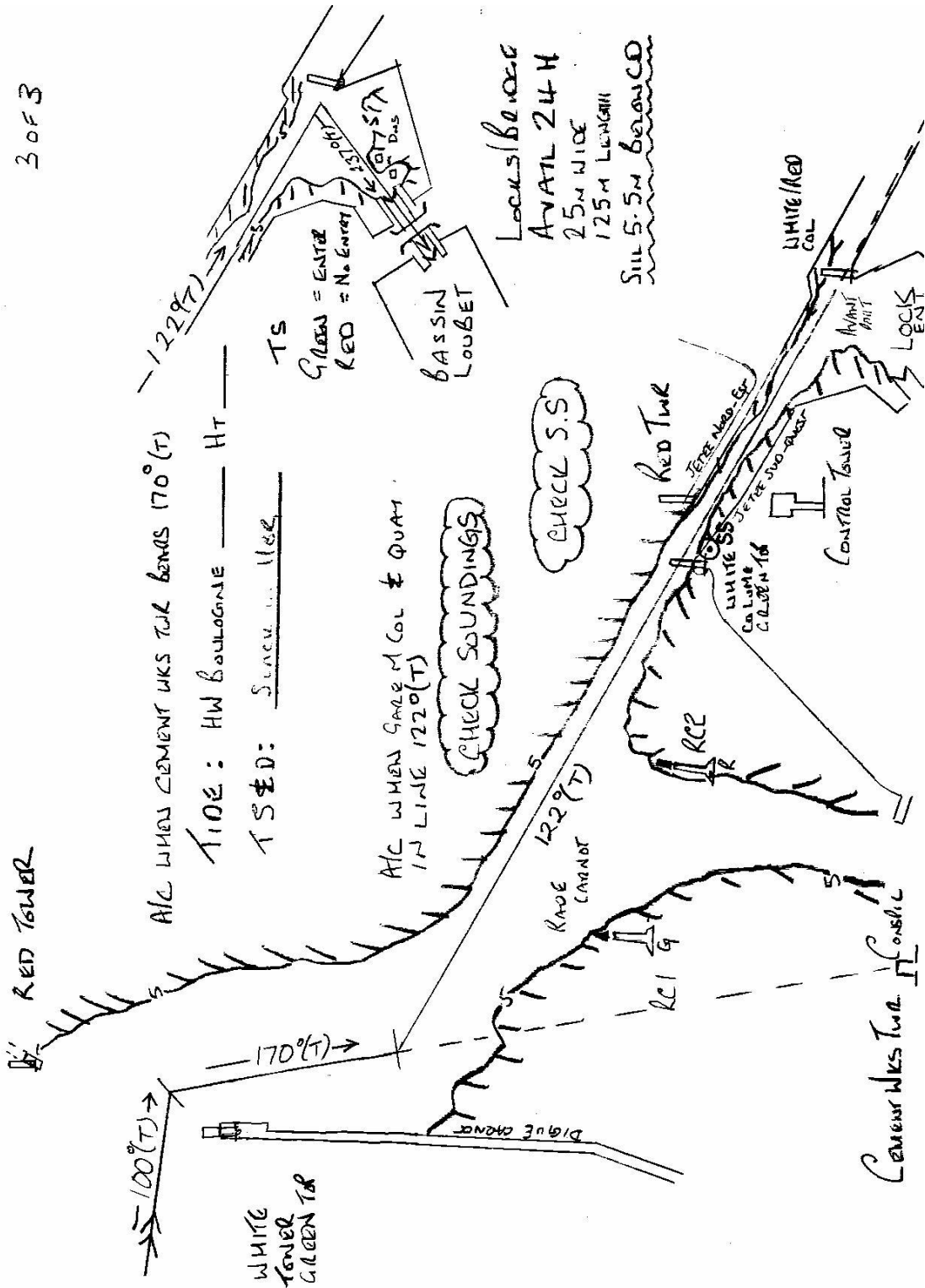

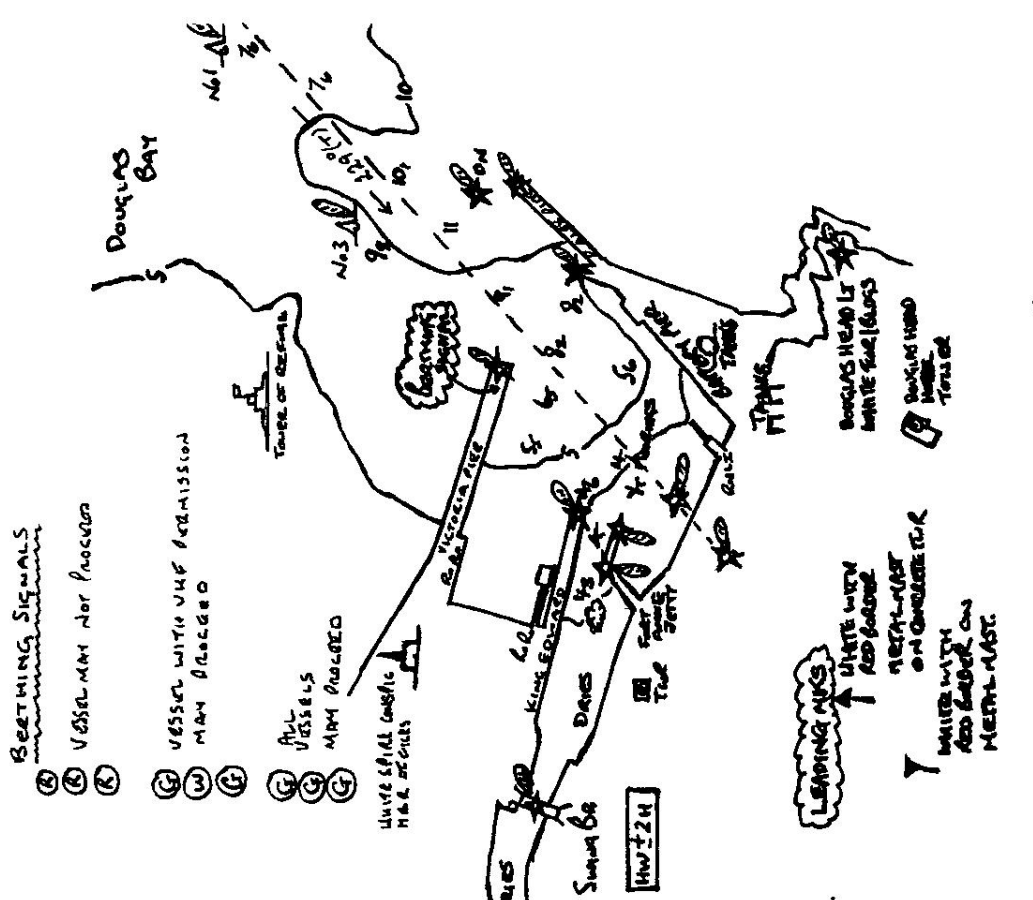

- BERTHING SIGNALS
- (A) VESSEL MAY NOT PROCEED
  - (B) VESSEL WITH VHF PERMISSION MAY PROCEED
  - (C) ALL VESSELS MAY PROCEED

**DOUGLAS IOM CH 12 "DOUGLAS HARBOUR"**

01624 686628  
 DATE 18.06.76...

HW L'POOL 1235 ± 8.7 m  
 DIFF DOUGLAS -0.4 -2.2 m  
 HW DOUGLAS 1331A 6.5 m

LW L'POOL 1856 ± 1.8 m  
 DIFF DOUGLAS -3.2 -0.3 m  
 LW DOUGLAS 1924A 1.5 m

R = 6.9 = M/S

HW DOVER 1319A

TS&D

MINIMUM EXPECTED DEPTH 9.8 m

BERTHING INSTRUCTIONS: ETA 1500A  
 Call Ch 12 2' off Head R. to R. Jettie @ 10.45  
 Corner Harb. when Secure. South E. of Head No. 4.

TRAFFIC NOTES:  
 AS LADY OF HAIN DUE  
 No other movements.

PILOTAGE NOTES

KEEP TO NORTH OF LINE FT ANNE JETTY TO  
 No. 4 BERTH ON BATTERY PIER

SA C41 28.12.97

APPENDIX 3

APPENDIX 3: A SAMPLE YACHTS CHECK LIST

**SAFETY EQUIPMENT**

Harnesses  
 harnesses ..... Num. \_\_\_\_\_  
 lines and fixings in cockpit ..... Num. \_\_\_\_\_

Flares  
 parachute rockets ..... Num. \_\_\_\_\_  
 hand held flares ..... Num. \_\_\_\_\_  
 buoyant smokes ..... Num. \_\_\_\_\_  
 orange smokes ..... Num. \_\_\_\_\_

Other  
 Dan Buoy ..... Num. \_\_\_\_\_  
 Lifebuoys ..... Num. \_\_\_\_\_  
 Life raft ..... located \_\_\_\_\_  
 Lifejackets ..... Num. \_\_\_\_\_  
 EPIRB ..... Num. \_\_\_\_\_  
 Fire extinguishers ..... Num. \_\_\_\_\_  
 Dry Powder ..... Num. \_\_\_\_\_  
 Halon ( ) ..... Num. \_\_\_\_\_  
 CO<sub>2</sub> ( ) ..... Num. \_\_\_\_\_  
 Fire Blanket ..... Num. \_\_\_\_\_  
 Automatic in Engine Compartment ..... Num. \_\_\_\_\_  
 VHF ..... Num. \_\_\_\_\_  
 Radar reflector ..... Num. \_\_\_\_\_

**NAVIGATION**

Navigation instruments  
 Compass ..... Num. \_\_\_\_\_  
 Hand-bearing compass ..... Num. \_\_\_\_\_  
 Deviation chart ..... Num. \_\_\_\_\_  
 Log ..... Type \_\_\_\_\_  
 Log location ..... Num. \_\_\_\_\_  
 Spare impeller ? ..... Num. \_\_\_\_\_  
 Walker Log backup ..... Num. \_\_\_\_\_  
 GPS ..... Manual \_\_\_\_\_  
 RDF ..... Manual \_\_\_\_\_  
 Lead-line ..... Manual \_\_\_\_\_

Navigation Tools  
 Parallel rulers ..... Num. \_\_\_\_\_  
 Bicon Plotter ..... Num. \_\_\_\_\_  
 Dividers ..... Num. \_\_\_\_\_

**SALES, AND RIGGING**

Head sail  
 Reeling ..... Num. \_\_\_\_\_  
 Genoa ..... Num. \_\_\_\_\_  
 Jib 1 ..... Num. \_\_\_\_\_  
 Jib 2 ..... Num. \_\_\_\_\_  
 Jib 3 ..... Num. \_\_\_\_\_  
 Jib 4 ..... Num. \_\_\_\_\_  
 Storm Jib ..... Num. \_\_\_\_\_

Mainsail  
 Reeling (Roller) ..... Num. \_\_\_\_\_  
 Sheets ..... Sub-O) ..... Num. \_\_\_\_\_

Rigging  
 Stays ..... Num. \_\_\_\_\_  
 forward stay ..... Num. \_\_\_\_\_  
 aft stay ..... Num. \_\_\_\_\_  
 Spare shackles ..... Num. \_\_\_\_\_  
 Spare sail battens ..... Num. \_\_\_\_\_

**ELECTRICAL SYSTEM**

Generation and storage  
 Batteries ..... Num. \_\_\_\_\_  
 Battery switch ..... Num. \_\_\_\_\_  
 Switch panel ..... Num. \_\_\_\_\_  
 Charge meter ..... Num. \_\_\_\_\_

Navigation lights  
 Masthead ..... Num. \_\_\_\_\_  
 Steaming ..... Num. \_\_\_\_\_  
 Compass lights ..... Num. \_\_\_\_\_  
 Deck lights ..... Num. \_\_\_\_\_

Other  
 Water pump ..... Num. \_\_\_\_\_  
 Electric Bilge pump ..... Num. \_\_\_\_\_  
 Spare bulbs ..... Num. \_\_\_\_\_  
 Distilled water ..... Num. \_\_\_\_\_

**AUXILIARY POWER**

Diesel operation ..... Num. \_\_\_\_\_  
 Keys ..... Num. \_\_\_\_\_  
 Fuel filter location ..... Num. \_\_\_\_\_  
 Stern Glants ..... Num. \_\_\_\_\_  
 Access ..... Num. \_\_\_\_\_  
 Hand starting / cranking ..... Num. \_\_\_\_\_

**SAFETY EQUIPMENT**

Galley  
 Cooker ..... Num. \_\_\_\_\_  
 Pans ..... Num. \_\_\_\_\_  
 Plates ..... Num. \_\_\_\_\_  
 Bowls ..... Num. \_\_\_\_\_  
 Glasses ..... Num. \_\_\_\_\_  
 Cups ..... Num. \_\_\_\_\_  
 Cutlery ..... Num. \_\_\_\_\_  
 Food Storage ..... Num. \_\_\_\_\_  
 Cold storage ..... Num. \_\_\_\_\_

Heads  
 Pump toilet ( slop cock ) ..... Num. \_\_\_\_\_  
 Shower ..... Num. \_\_\_\_\_

Other  
 Sleeping bags ..... Num. \_\_\_\_\_  
 Sleeping bag liners ..... Num. \_\_\_\_\_  
 Cushions ..... Num. \_\_\_\_\_

**FUELS AND FLUIDS**

Diesel ..... Ltr \_\_\_\_\_  
 Gas ..... Bottles \_\_\_\_\_  
 Fresh Water ..... Ltr \_\_\_\_\_  
 Petrol for outboard ..... Ltr \_\_\_\_\_  
 Two-stroke oil ..... Ltr \_\_\_\_\_  
 Funnel ..... Num. \_\_\_\_\_  
 Dipstick ..... Num. \_\_\_\_\_

**DECK GEAR**

Anchor ..... Chain \_\_\_\_\_  
 Spare anchor ..... Num. \_\_\_\_\_  
 Fenders ..... Num. \_\_\_\_\_  
 Warps ..... Num. \_\_\_\_\_  
 Boat hooks ..... Num. \_\_\_\_\_  
 Winch handles ..... Num. \_\_\_\_\_  
 Boarding ladder ..... Num. \_\_\_\_\_  
 Ensign ..... Num. \_\_\_\_\_  
 Tender ..... Num. \_\_\_\_\_  
 Tender outboard ..... Num. \_\_\_\_\_  
 Oars ..... Num. \_\_\_\_\_

**AUXILIARY GEAR**

Hand bilge pump ..... Num. \_\_\_\_\_  
 Tools ..... Num. \_\_\_\_\_  
 Bolt cutters ..... Num. \_\_\_\_\_  
 Pliers ..... Num. \_\_\_\_\_  
 Socket set ..... Num. \_\_\_\_\_  
 Screw drivers ..... Num. \_\_\_\_\_  
 Spanners ..... Num. \_\_\_\_\_  
 Insulating tape ..... Num. \_\_\_\_\_  
 Duct tape ..... Num. \_\_\_\_\_  
 Bosons cloth ..... Num. \_\_\_\_\_

**NOTES**

.....  
 .....  
 .....  
 .....  
 .....

# **ANNEX A**

## **SAFE WORKING LOADS OF RIGGING EQUIPMENT**

- 1. Straight Screw Shackle**
- 2. Straight Shackle with Pin and Forelock**
- 3. Straight Shackle with Split Pin**
- 4. Bow Screw Shackle**
- 5. Bow Shackle with Pin and Forelock**
- 6. Bow Shackle with Spilt Pin**
- 7. SWL of Blocks in Various Tackle Configurations**
- 8. SWL of Blocks in Various Tackle Configurations**
- 9. Natural Fibre Cordage**
- 10. Polyamide Ropes**
- 11. Polyester Ropes**
- 12. Polypropylene Ropes**
- 13. Polyethylene Ropes**



# 1. Straight Screw Shackle

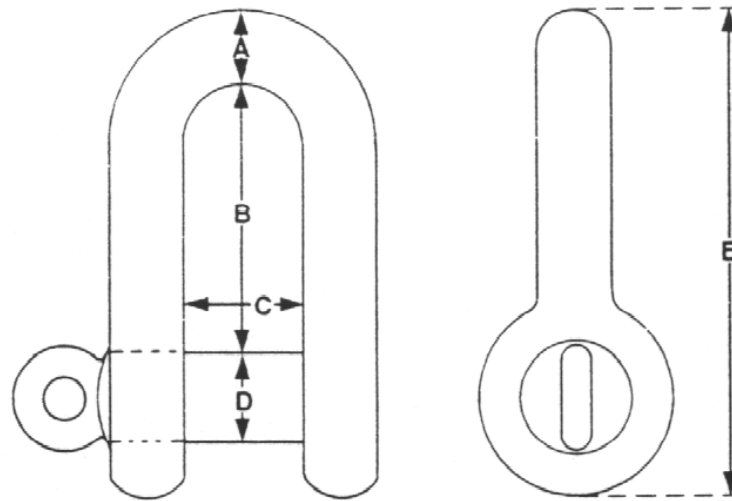

Naval Stores No	Nominal Size	Dimensions				SWL
		A	B	C	D	
	mm	mm	mm	mm	mm	tonnes
0263/721-6087	6	24	10	10	45	0.3
0263/721-6088	10	35	16	13	64	0.6
0263/721-6089	13	46	21	16	83	1.05
0263/721-6090	16	57	25	19	102	1.8
0263/721-6091	19	68	31	25	125	2.55
0263/721-6092	22	81	36	29	146	3.55
0263/721-6093	25	92	41	32	165	4.6
0263/733-1299	29	103	46	35	184	5.6
0263/721-6094	32	114	51	38	203	7.1
0263/721-6095	35	125	56	44	226	8.15
0263/721-6096	38	138	61	48	248	10.9
0263/721-6097	41	149	67	51	266	13.2
0263/721-6098	44	160	71	54	285	15.0
0263/721-6099	48	171	76	57	305	17.0
0263/721-6100	51	183	82	64	330	19.5

## Straight Shackle with Pin and Forelock

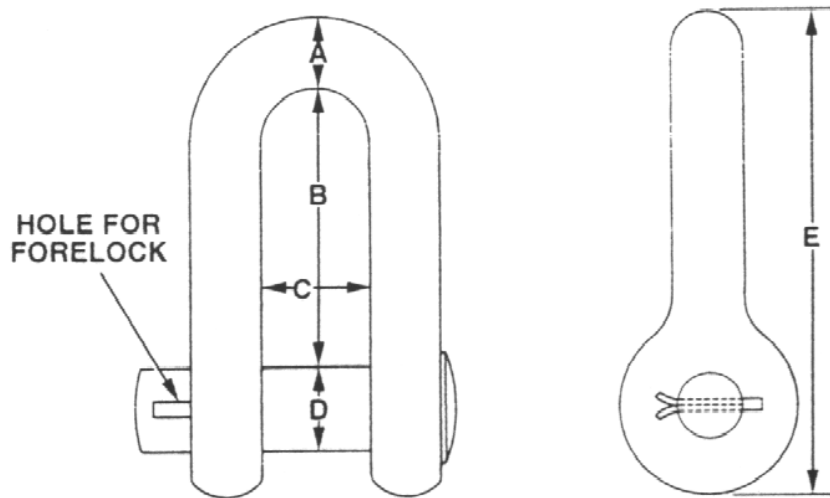

Naval Stores No	Nominal Size	Dimensions				SWL
		A	B	C	D	
	mm	mm	mm	mm	mm	tonnes
0263/543-4298	13	46	21	16	83	1.05
0263/543-4299	19	68	31	25	125	2.55
0263/543-4300	25	92	41	32	165	4.6
0263/543-4301	32	114	51	38	203	7.1
0263/543-4302	38	138	61	48	248	10.9
0263/543-4303	44	160	71	54	285	15.0
0263/543-4304	50	183	82	64	329	19.5

## Straight Shackle with Split Pin

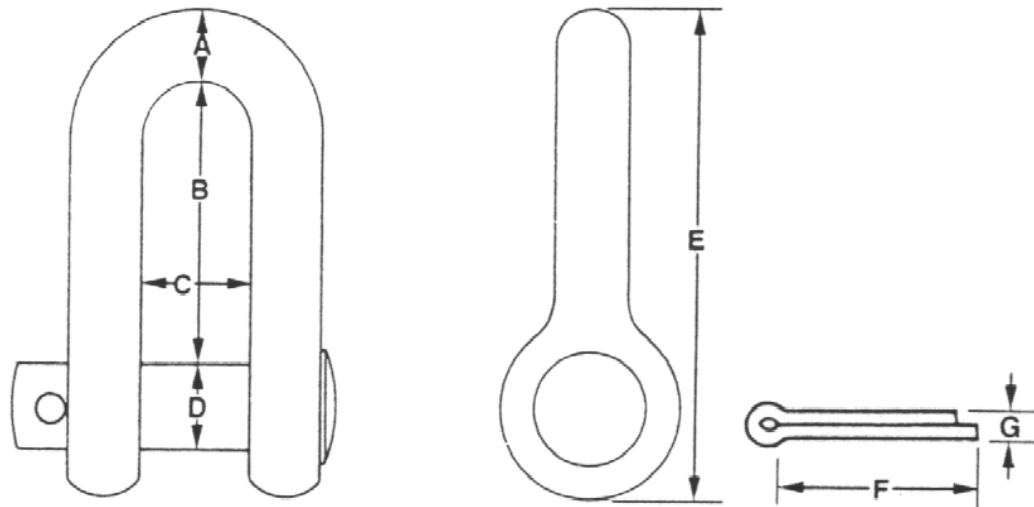

Naval Stores No	Nominal Size	Dimensions						SWL
		A	B	C	D	E	F	
	mm	mm	mm	mm	mm	mm	mm	tonnes
0263/543-4528	6	24	10	10	45	15	2.5	0.3
0263/543-4529	10	35	16	13	64	20	4.0	0.6
0263/543-4530	13	46	21	16	83	25	4.0	1.05
0263/543-4531	16	57	25	19	102	30	4.0	1.8
0263/543-4532	19	68	31	25	125	40	5.0	2.55
0263/543-4533	22	81	36	29	146	45	5.0	3.55
0263/543-4534	25	92	41	32	165	50	5.0	4.6
0263/543-4535	29	103	46	35	184	55	6.3	5.6
0263/543-4536	32	114	51	38	203	60	6.3	7.1
0263/543-4537	35	125	56	44	226	70	6.3	8.15
0263/543-4538	38	138	61	48	248	75	8.0	10.9
0263/543-4539	41	149	67	51	266	80	8.0	13.2
0263/543-4540	44	160	71	54	285	85	13.0	15.0
0263/543-4541	48	171	76	57	305	90	13.0	17.0
0263/543-4542	51	183	82	64	330	100	13.0	19.5
0263/543-4543	54	216	87	67	349	105	13.0	20.5
0263/543-4544	57	228	92	70	372	110	13.0	23.0
0263/543-4545	60	241	97	73	395	115	13.0	25.5

## Bow Screw Shackle

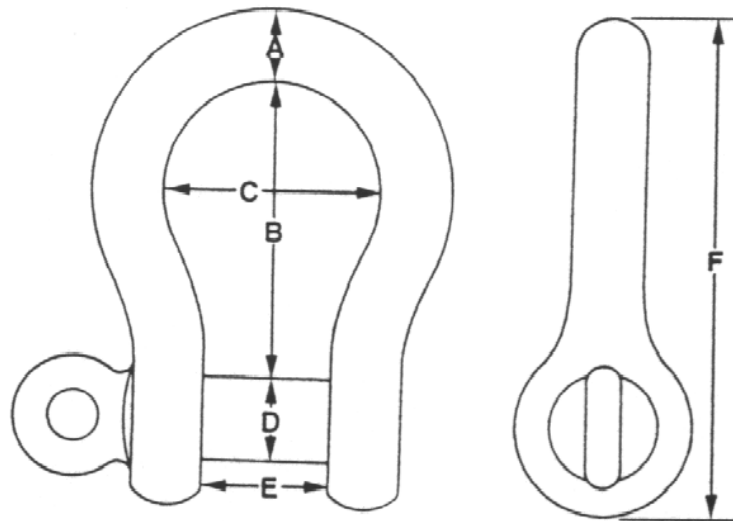

Naval Stores No	Nominal Size	Dimensions					SWL
	A	B	C	D	E	F	
	mm	mm	mm	mm	mm	mm	tonnes
0263/721-6101	6	25	19	10	13	46	0.15
0263/721-6102	10	38	29	13	17	67	0.45
0263/721-6103	13	51	38	16	24	88	0.75
0263/721-6104	16	64	48	19	29	109	1.25
0263/721-6105	19	76	57	25	35	133	2.05
0263/721-6106	22	89	67	29	41	154	2.80
0263/721-6107	25	102	76	32	46	175	3.80
0263/721-6108	29	114	86	35	52	195	4.85
0263/721-6109	32	127	95	38	57	216	5.85
0263/721-6110	35	140	105	44	64	241	7.35
0263/721-6111	38	152	114	48	70	262	8.65
0263/721-6112	41	165	124	51	75	282	9.65
0263/721-6113	44	178	133	54	81	303	11.7
0263/721-6114	48	191	143	57	86	326	13.2
0263/721-6115	51	203	152	64	92	350	15.25

## Bow Shackle with Pin and Forelock

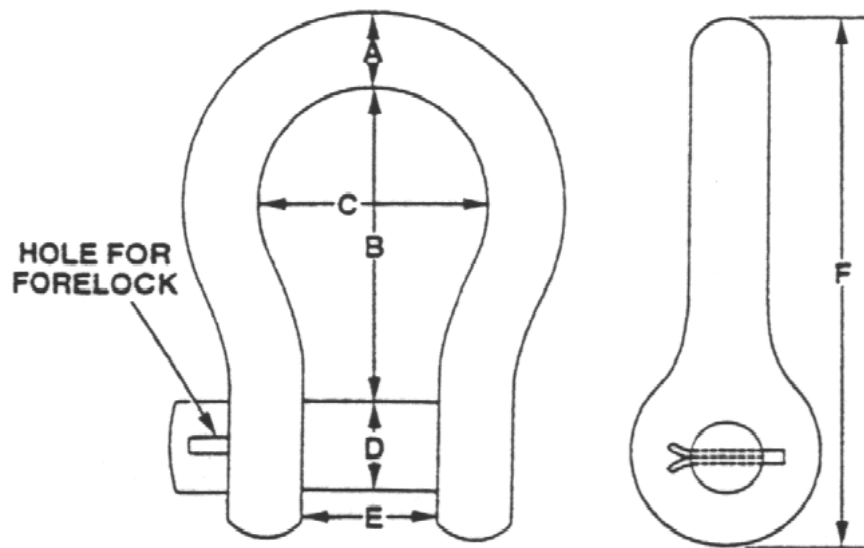

Naval Stores No	Nominal Size	Dimensions							SWL
		A	B	C	D	E	F	G	
	mm	mm	mm	mm	mm	mm	mm	mm	tonnes
0263/543-4291	13	51	38	16	24	88	0.75	13	51
0263/543-4292	19	75	57	25	35	132	2.05	19	75
0263/543-4293	25	102	76	32	46	175	3.80	25	102
0263/543-4294	32	127	95	38	57	216	5.85	32	127
0263/543-4295	38	152	114	48	70	262	8.65	38	152
0263/543-4296	44	178	133	54	81	303	11.70	44	178
0263/543-4297	51	203	152	64	92	349	15.25	51	203

## Bow Shackle with Split Pin

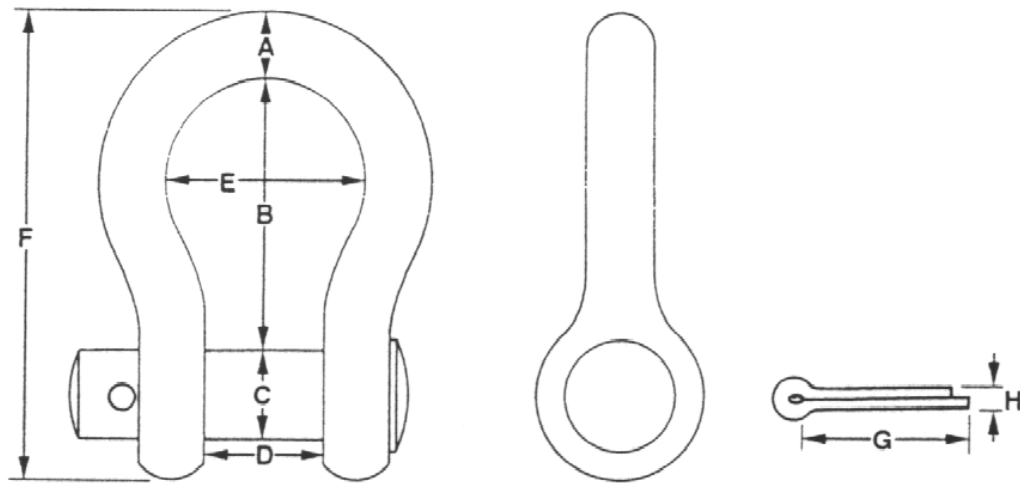

Naval Stores No	Nominal Size	Dimensions							SWL
		A	B	C	D	E	F	G	
	mm	mm	mm	mm	mm	mm	mm	mm	tonnes
0263/543-4546	6	25	10	13	19	46	15	2.5	0.15
0263/543-4547	10	38	13	17	29	67	20	4.0	0.45
0263/543-4548	13	51	16	24	38	88	25	4.0	0.75
0263/543-4549	16	64	19	29	48	109	30	4.0	1.25
0263/543-4550	19	76	25	35	57	133	40	5.0	2.05
0263/543-4551	22	89	29	41	67	154	45	5.0	2.8
0263/543-4552	25	102	32	46	76	175	50	5.0	3.8
0263/543-4553	29	114	35	52	86	195	55	6.3	4.85
0263/543-4554	32	127	38	57	95	216	60	6.3	5.85
0263/543-4555	35	140	44	64	105	241	70	6.3	7.35
0263/543-4556	38	152	48	70	114	262	75	8.0	8.65
0263/543-4557	41	165	51	75	124	282	80	8.0	9.65
0263/543-4558	44	178	54	81	133	303	85	13.0	11.7
0263/543-4559	48	191	57	86	143	325	90	13.0	13.2
0263/543-4560	51	203	64	92	152	350	100	13.0	15.25
0263/543-4561	64	254	76	114	191	432	115	13.0	22.85

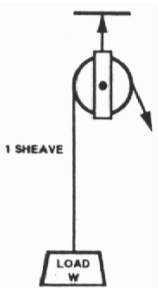
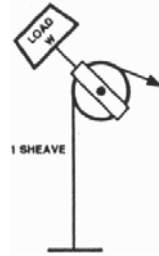
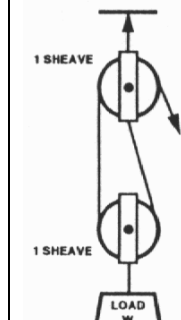
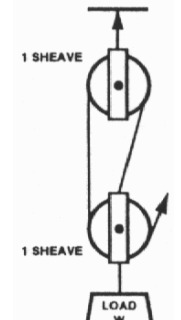
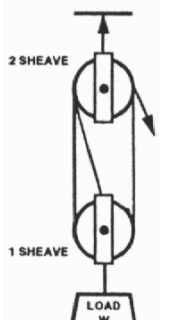
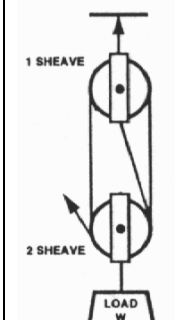

**MAXIMUM LOAD TO BE LIFTED (TONNES)**

(Assuming standing and moving blocks are of the same SWL, and fall is of the required strength)

NATO STOCK No	SWL ON HEAD FITTINGS TONNES	PROOF LOAD TONNES	SINGLE WHIP	RUNNER	DOUBLE WHIP (D)	DOUBLE WHIP (A)	LUFF/JIGGER/HANDY BILLY (D)	LUFF/JIGGER/HANDY BILLY (A)
								
0246/521-2794	1.0	2.0	0.5	1.0				
/521-2795	2.0	4.0	1.0	2.0				
/521-2796	4.0	8.0	2.0	4.0				
/521-0663	2.0	4.0	1.0	2.0				
/521-0664	4.0	8.0	2.0	4.0				
/521-0665	6.0	12.0	3.0	6.0				
/463-3880	0.315	0.63	0.158	0.315				
0246/521-0660	2.0	4.0	1.0	2.0	1.33	2.0	1.5	2.0
/521-0661	4.0	8.0	2.0	4.0	2.67	4.0	3.0	4.0
/521-0662	6.0	12.0	3.0	6.0	4.0	6.0	4.5	6.0
/463-3858	0.375	0.75	0.188	0.375	0.25	0.375	0.28	0.375
/521-2797	1.0	2.0	0.5	1.0	0.67	1.0	0.75	1.0
/521-2798	2.0	4.0	1.0	2.0	1.33	2.0	1.5	2.0
/521-2799	4.0	8.0	2.0	4.0	2.67	4.0	3.0	4.0

**MAXIMUM LOAD TO BE LIFTED (TONNES)**

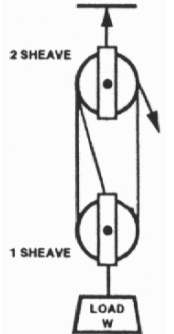
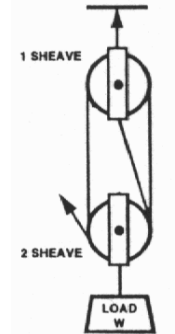
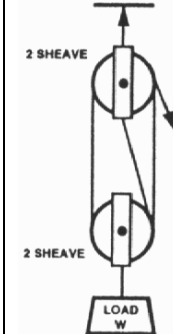
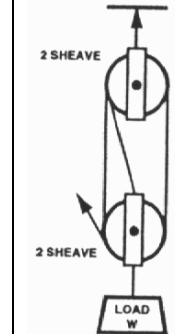
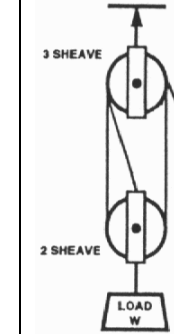
(Assuming standing and moving blocks are of the same SWL, and fall is of the required strength)

NATO STOCK No	SWL ON HEAD FITTINGS TONNES	PROOF LOAD TONNES	LUFF/ JIGGER/ HANDY BILLY (D)	LUFF/ JIGGER/ HANDY BILLY (A)	TWO FOLD PURCHASE (D)	TWO FOLD PURCHASE (A)	3 X 2 PURCHASE (D)	3 X 2 PURCHASE (A)
								
0246/463-3860	0.65	1.3	0.488	0.65	0.52	0.65	0.54	0.65
/463-3870	1.75	3.5	1.313	1.75	1.4	1.75	1.458	1.75
/463-3876	0.5	1.0	0.375	0.5	0.4	0.5	0.417	0.5
/463-3878	1.0	2.0	0.75	1.0	0.8	1.0		
/463-3881	0.5	1.0	0.375	0.5	0.4	0.5		
0246/521-2791	1.0	2.0	0.75	1.0	0.8	1.0	0.83	1.0
/521-2792	2.0	4.0	1.5	2.0	1.6	2.0	1.67	2.0
/521-2793	4.0	8.0	3.0	4.0	3.2	4.0	3.33	4.0
/441-9645	0.15	0.3	0.113	0.15	0.12	0.15		
/525-0093	0.228	0.456	0.171	0.228	0.182	0.182		
0579/539-9821	1.0	2.0	0.75	1.0	0.8	1.0	0.83	1.0



## Natural Fibre Cordage

Type	Size	Naval Stores No	Minimum breaking load	Supply denomination
Manila	8mm	0350/571-3074	0.45 tonnes	220m
	12mm	0350/125-0228	1.06 tonnes	220m
	16mm	0350/942-5025	2.03 tonnes	220m
	20mm	0350/571-3077	3.25 tonnes	220m
	24mm	0350/942-5026	4.57 tonnes	220m
Sisal	5mm	0350/942-5039	0.33 tonnes	220m
	12mm	0350/942-5042	0.95 tonnes	220m
	16mm	0350/942-5044	1.80 tonnes	220m
	20mm	0350/942-5046	2.85 tonnes	220m
	24mm	0350/942-5048	4.07 tonnes	220m
	28mm	0350/942-5050	5.33 tonnes	220m
	72mm	0350/942-5060	32.7 tonnes	220m
Coir	16mm	0350/571-3032	N/A	220m
	24mm	0350/571-3034	N/A	220m
	20mm	0350/942-5018	N/A	220m
	24mm	0350/571-3034	N/A	220m
	32mm	0350/942-5019	N/A	220m
	40mm	0350/942-5020	N/A	220m
	48mm	0350/942-5021	N/A	220m
	64mm	0350/571-3041	N/A	220m
	80mm	0350/571-3042	N/A	220m

## Polyamide Ropes

Type	Size	Naval Stores No	Minimum breaking load	Supply denomination
Polyamide H/L	6mm	0350/923-7119	0.75 tonnes	220m
Polyamide H/L	8mm	0350/923-7121	1.35 tonnes	220m
Polyamide H/L	10mm	0350/923-7123	2.08 tonnes	220m
Polyamide H/L	12mm	0350/923-7124	3.00 tonnes	220m
Polyamide H/L	16mm	0350/923-7126	5.30 tonnes	220m
Polyamide H/L	20mm	0350/923-7128	8.30 tonnes	220m
Polyamide H/L	24mm	0350/923-7129	12.0 tonnes	220m
Polyamide H/L	28mm	0350/923-7130	15.8 tonnes	220m
Polyamide H/L	32mm	0350/923-7131	20.0 tonnes	220m
Polyamide H/L	36mm	0350/923-7132	24.8 tonnes	220m
Polyamide H/L	40mm	0350/923-7133	30.0 tonnes	220m
Polyamide H/L	44mm	0350/923-7134	35.8 tonnes	220m
Polyamide H/L	56mm	0350/923-7136	56.0 tonnes	220m
Polyamide H/L	64mm	0350/923-7137	72.0 tonnes	220m
Polyamide braided	21mm	0350/549-1 143	9.50 tonnes	160m
Polyamide braided	40mm	0350/251-4429	36.0 tonnes	65m*
Polyamide braided	56mm	0350/251-4430	69.0 tonnes	65m*
Polyamide braided	64mm	0350/251-4431	90.0 tonnes	65m*
Polyamide multi-plait	48mm	0350/794-8239	42.0 tonnes	220m
Polyamide multi-plait	64mm	0350/543-0143	72.0 tonnes	220m
Polyamide multi-plait	72mm	0350/543-0150	90.0 tonnes	220m
Polyamide multi-plait	80mm	0350/543-0149	110.0 tonnes	220m
Polyamide cord gunline	1.5mm	0350/571-3024	64 kg	160m 860m

## Polyester Ropes

Type	Size	Naval Stores No	Minimum breaking load	Supply denomination
Polyester H/L	5mm	0350/923-7140	0.40 tonnes	220m
Polyester H/L	8mm	0350/923-7142	1.02 tonnes	220m
Polyester H/L	12mm	0350/923-7143	2.27 tonnes	220m
Polyester H/L	16mm	0350/923-7144	4.1 tonnes	220m
Polyester H/L	20mm	0350/923-7145	6.3 tonnes	220m
Polyester Superline	32mm	0350/744-2499	24.0 tonnes	156m
Polyester Superline	16mm	0350/746-5139	7.0 tonnes	220m
Polyester 8 plait blue	8mm	0350/529-7387	0.39 tonnes	150m
Polyester 16 plait blue	10mm	0350/529-7388	2.25 tonnes	150m
Polyester 16 plait blue	12mm	0350/529-7389	3.20 tonnes	150m
Polyester 16 plait blue	14mm	0350/529-7390	4.40 tonnes	150m
Polyester 16 plait blue	20mm	0350/529-7391	8.10 tonnes	150m
Polyester 8 plait red	6mm	0350/529-7392	0.30 tonnes	150m
Polyester 8 plait red	8mm	0350/529-7393	0.39 tonnes	150m
Polyester 16 plait red	10mm	0350/529-7394	2.25 tonnes	150m
Polyester 16 plait red	12mm	0350/529-7395	3.20 tonnes	150m
Polyester 16 plait red	14mm	0350/529-7396	4.40 tonnes	150m
Polyester 16 plait gold	12mm	0350/529-7397	3.20 tonnes	150m
Polyester 16 plait gold	14mm	0350/529-7398	4.40 tonnes	150m
Polyester 8 plait white	6mm	0350/529-7399	0.47 tonnes	150m
Polyester 8 plait white	8mm	0350/529-7400	0.56 tonnes	150m
Polyester 16 plait white	10mm	0350/529-7401	2.25 tonnes	150m
Polyester 16 plait white	12mm	0350/529-7402	3.20 tonnes	150m
Polyester 16 plait white	14mm	0350/529-7404	4.40 tonnes	150m
Polyester braided	5mm	0350/ 120-8768	0.40 tonnes	150m
Polyester braided	7mm	0350/571-3167	0.70 tonnes	150m
Polyester braided	8.5m	0350/120-8692	0.79 tonnes	150m
Polyester braided	16mm	0350/939-2764	4.1 tonnes	150m
Polyester cord	1.5mm	0350/520-9610	0.14 tonnes	510m

## Polypropylene Ropes

Type	Size	Naval Stores No	Minimum breaking load	Supply denomination
Polypropylene H/L *	16mm	0350/075-0861	3.5 tonnes	220m
Polypropylene H/L *	20mm	0350/906-7361	5.37 tonnes	220m
Polypropylene H/L *	24mm	0350/375-2994	7.6 tonnes	220m
Polypropylene H/L	8mm	0350/529-9737	0.96 tonnes	220m
Polypropylene H/L	10mm	0350/447-1147	1.42 tonnes	220m
Polypropylene H/L	12mm	0350/525-6204	2.03 tonnes	220m
Polypropylene H/L	16mm	0350/571-3172	3.5 tonnes	220m
Polypropylene H/L	20mm	0350/906-7361	5.37 tonnes	220m

## Polyethylene Ropes

Type	Size	Naval Stores No	Minimum breaking load	Supply denomination
Polyethylene H/L Orange	4mm	0350/571-3169	0.20 tonnes	300m
Polyethylene H/L Orange	8mm	0350/543-0141	0.70 tonnes	220m
Polyethylene H/L Orange	10mm	0350/571-3171	1.08 tonnes	220m

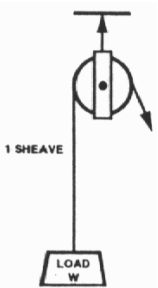
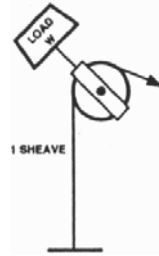
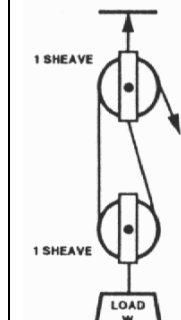
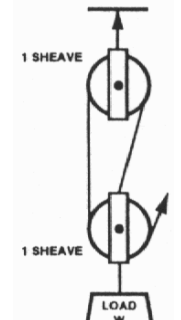
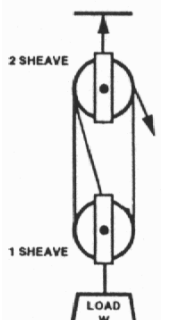
			<b>MAXIMUM LOAD TO BE LIFTED (TONNES)</b>					
			(Assuming standing and moving blocks are of the same SWL, and fall is of the required strength)					
NATO STOCK No	SWL ON HEAD FITTINGS	PROOF LOAD	SINGLE WHIP	RUNNER	DOUBLE WHIP (D)	DOUBLE WHIP (A)	LUFF/JIGGER/HANDY BILLY (D)	LUFF/JIGGER/HANDY BILLY (A)
	TONNES		TONNES					
0246/521-2794	1.0	2.0	0.5	1.0				
/521-2795	2.0	4.0	1.0	2.0				
/521-2796	4.0	8.0	2.0	4.0				
/521-0663	2.0	4.0	1.0	2.0				
/521-0664	4.0	8.0	2.0	4.0				
/521-0665	6.0	12.0	3.0	6.0				
/463-3880	0.315	0.63	0.158	0.315				
0246/521-0660	2.0	4.0	1.0	2.0	1.33	2.0	1.5	2.0
/521-0661	4.0	8.0	2.0	4.0	2.67	4.0	3.0	4.0
/521-0662	6.0	12.0	3.0	6.0	4.0	6.0	4.5	6.0
/463-3858	0.375	0.75	0.188	0.375	0.25	0.375	0.28	0.375
/521-2797	1.0	2.0	0.5	1.0	0.67	1.0	0.75	1.0
/521-2798	2.0	4.0	1.0	2.0	1.33	2.0	1.5	2.0
/521-2799	4.0	8.0	2.0	4.0	2.67	4.0	3.0	4.0
			<b>MAXIMUM LOAD TO BE LIFTED (TONNES)</b>					
			(Assuming standing and moving blocks are of the same SWL, and fall is of the required strength)					
			LUFF/	LUFF/	TWO FOLD	TWO FOLD	3 X 2	3 X 2

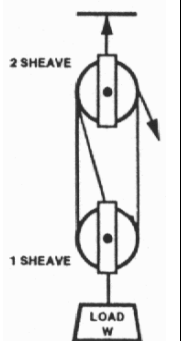
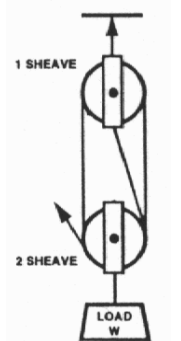
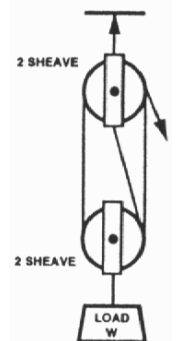
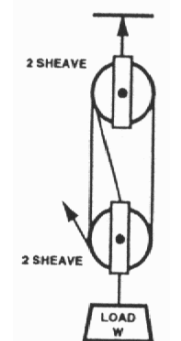
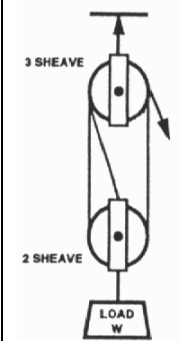
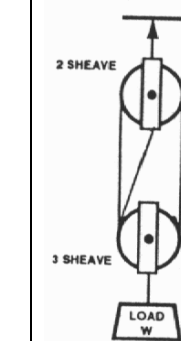
NATO STOCK No	SWL ON HEAD FITTINGS TONNES	PROOF LOAD TONNES	JIGGER/ HANDY BILLY (D)	JIGGER/ HANDY BILLY (A)	PURCHASE (D)	PURCHASE (A)	PURCHASE (D)	PURCHASE (A)
								
0246/463-3860	0.65	1.3	0.488	0.65	0.52	0.65	0.54	0.65
/463-3870	1.75	3.5	1.313	1.75	1.4	1.75	1.458	1.75
/463-3876	0.5	1.0	0.375	0.5	0.4	0.5	0.417	0.5
/463-3878	1.0	2.0	0.75	1.0	0.8	1.0		
/463-3881	0.5	1.0	0.375	0.5	0.4	0.5		
0246/521-2791	1.0	2.0	0.75	1.0	0.8	1.0	0.83	1.0
/521-2792	2.0	4.0	1.5	2.0	1.6	2.0	1.67	2.0
/521-2793	4.0	8.0	3.0	4.0	3.2	4.0	3.33	4.0
/441-9645	0.15	0.3	0.113	0.15	0.12	0.15		
/525-0093	0.228	0.456	0.171	0.228	0.182	0.182		
0579/539-9821	1.0	2.0	0.75	1.0	0.8	1.0	0.83	1.0

## Natural Fibre Cordage

Type	Size	Naval Stores No	Minimum breaking load	Supply denomination
Manila	8mm	0350/571-3074	0.45 tonnes	220m
	12mm	0350/125-0228	1.06 tonnes	220m
	16mm	0350/942-5025	2.03 tonnes	220m
	20mm	0350/571-3077	3.25 tonnes	220m
	24mm	0350/942-5026	4.57 tonnes	220m
Sisal	5mm	0350/942-5039	0.33 tonnes	220m
	12mm	0350/942-5042	0.95 tonnes	220m
	16mm	0350/942-5044	1.80 tonnes	220m
	20mm	0350/942-5046	2.85 tonnes	220m
	24mm	0350/942-5048	4.07 tonnes	220m
	28mm	0350/942-5050	5.33 tonnes	220m
	72mm	0350/942-5060	32.7 tonnes	220m
Coir	16mm	0350/571-3032	N/A	220m
	24mm	0350/571-3034	N/A	220m
	20mm	0350/942-5018	N/A	220m
	24mm	0350/571-3034	N/A	220m
	32mm	0350/942-5019	N/A	220m
	40mm	0350/942-5020	N/A	220m
	48mm	0350/942-5021	N/A	220m
	64mm	0350/571-3041	N/A	220m
80mm	0350/571-3042	N/A	220m	

## Polyamide Ropes

Type	Size	Naval Stores No	Minimum breaking load	Supply denomination
Polyamide H/L	6mm	0350/923-7119	0.75 tonnes	220m
Polyamide H/L	8mm	0350/923-7121	1.35 tonnes	220m
Polyamide H/L	10mm	0350/923-7123	2.08 tonnes	220m
Polyamide H/L	12mm	0350/923-7124	3.00 tonnes	220m
Polyamide H/L	16mm	0350/923-7126	5.30 tonnes	220m
Polyamide H/L	20mm	0350/923-7128	8.30 tonnes	220m
Polyamide H/L	24mm	0350/923-7129	12.0 tonnes	220m
Polyamide H/L	28mm	0350/923-7130	15.8 tonnes	220m
Polyamide H/L	32mm	0350/923-7131	20.0 tonnes	220m
Polyamide H/L	36mm	0350/923-7132	24.8 tonnes	220m
Polyamide H/L	40mm	0350/923-7133	30.0 tonnes	220m
Polyamide H/L	44mm	0350/923-7134	35.8 tonnes	220m
Polyamide H/L	56mm	0350/923-7136	56.0 tonnes	220m
Polyamide H/L	64mm	0350/923-7137	72.0 tonnes	220m
Polyamide braided	21mm	0350/549-1 143	9.50 tonnes	160m
Polyamide braided	40mm	0350/251-4429	36.0 tonnes	65m*
Polyamide braided	56mm	0350/251-4430	69.0 tonnes	65m*
Polyamide braided	64mm	0350/251-4431	90.0 tonnes	65m*
Polyamide multi-plait	48mm	0350/794-8239	42.0 tonnes	220m
Polyamide multi-plait	64mm	0350/543-0143	72.0 tonnes	220m
Polyamide multi-plait	72mm	0350/543-0150	90.0 tonnes	220m
Polyamide multi-plait	80mm	0350/543-0149	110.0 tonnes	220m
Polyamide cord gunline	1.5mm	0350/571-3024	64 kg	160m 860m



## Polyester Ropes

Type	Size	Naval Stores No	Minimum breaking load	Supply denomination
Polyester H/L	5mm	0350/923-7140	0.40 tonnes	220m
Polyester H/L	8mm	0350/923-7142	1.02 tonnes	220m
Polyester H/L	12mm	0350/923-7143	2.27 tonnes	220m
Polyester H/L	16mm	0350/923-7144	4.1 tonnes	220m
Polyester H/L	20mm	0350/923-7145	6.3 tonnes	220m
Polyester Superline	32mm	0350/744-2499	24.0 tonnes	156m
Polyester Superline	16mm	0350/746-5139	7.0 tonnes	220m
Polyester 8 plait blue	8mm	0350/529-7387	0.39 tonnes	150m
Polyester 16 plait blue	10mm	0350/529-7388	2.25 tonnes	150m
Polyester 16 plait blue	12mm	0350/529-7389	3.20 tonnes	150m
Polyester 16 plait blue	14mm	0350/529-7390	4.40 tonnes	150m
Polyester 16 plait blue	20mm	0350/529-7391	8.10 tonnes	150m
Polyester 8 plait red	6mm	0350/529-7392	0.30 tonnes	150m
Polyester 8 plait red	8mm	0350/529-7393	0.39 tonnes	150m
Polyester 16 plait red	10mm	0350/529-7394	2.25 tonnes	150m
Polyester 16 plait red	12mm	0350/529-7395	3.20 tonnes	150m
Polyester 16 plait red	14mm	0350/529-7396	4.40 tonnes	150m
Polyester 16 plait gold	12mm	0350/529-7397	3.20 tonnes	150m
Polyester 16 plait gold	14mm	0350/529-7398	4.40 tonnes	150m
Polyester 8 plait white	6mm	0350/529-7399	0.47 tonnes	150m
Polyester 8 plait white	8mm	0350/529-7400	0.56 tonnes	150m
Polyester 16 plait white	10mm	0350/529-7401	2.25 tonnes	150m
Polyester 16 plait white	12mm	0350/529-7402	3.20 tonnes	150m
Polyester 16 plait white	14mm	0350/529-7404	4.40 tonnes	150m
Polyester braided	5mm	0350/ 120-8768	0.40 tonnes	150m
Polyester braided	7mm	0350/571-3167	0.70 tonnes	150m
Polyester braided	8.5m	0350/120-8692	0.79 tonnes	150m
Polyester braided	16mm	0350/939-2764	4.1 tonnes	150m
Polyester cord	1.5mm	0350/520-9610	0.14 tonnes	510m

## Polypropylene Ropes

Type	Size	Naval Stores No	Minimum breaking load	Supply denomination
Polypropylene H/L *	16mm	0350/075-0861	3.5 tonnes	220m
Polypropylene H/L *	20mm	0350/906-7361	5.37 tonnes	220m
Polypropylene H/L *	24mm	0350/375-2994	7.6 tonnes	220m
Polypropylene H/L	8mm	0350/529-9737	0.96 tonnes	220m
Polypropylene H/L	10mm	0350/447-1147	1.42 tonnes	220m
Polypropylene H/L	12mm	0350/525-6204	2.03 tonnes	220m
Polypropylene H/L	16mm	0350/571-3172	3.5 tonnes	220m
Polypropylene H/L	20mm	0350/906-7361	5.37 tonnes	220m

## Polyethylene Ropes

Type	Size	Naval Stores No	Minimum breaking load	Supply denomination
Polyethylene H/L Orange	4mm	0350/571-3169	0.20 tonnes	300m
Polyethylene H/L Orange	8mm	0350/543-0141	0.70 tonnes	220m
Polyethylene H/L Orange	10mm	0350/571-3171	1.08 tonnes	220m

# ANNEX B

## STORES NUMBERS FOR EQUIPMENT

Item	Stores Number	Supply Denom.
Flax Seaming Twine – Fine	0350/571-3269	250gm Cops
Flax Whipping Twine – Medium	0350/571-3270	250gm Cops
Flax Roping Twine - Course	0350/571-3267	250gm Cops
Twine Hemp	0330/533-2358	
Twine Polypropelene	0330/533-2360	
Sisal Spun yarn 3 Strand	0350/722-2646	6kg Skeins
Sisal Spun yarn 6 Strand	0350/722-2649	6kg Skeins
Rope - Sisal 8mm	0350/529-9737	
Rope - Sisal 12mm	0350/942-5042	
Rope - Sisal 16mm	0350/942-5044	
Rope - Sisal 32mm	0350/942-5051	
Knives - Sailmaker's	0275/910-5292	
Knives - Rigger's	0273/437-5839	
Marlin Spikes - 9inch	0273/910-5444	
Fid- Splicing - 10 inch	0273/910-4594	
Pricker 5 inch	0273/910-5544	
Pricker 3 inch	0273/910-5543	
Palm Seaming	0273/437-5868	
Palm Roping	0273/437-5867	
Needles – Straight – Size 11	0247/522-4327	
Size 13	0247/522-4326	
Needles Assorted	0275/923-9064	Pack
Hooks - Sailmaker's	0273/910-4761	
Brass Grommets - Spur/Tooth	0250/411-9617	
Sizes 000 to 8	to 9623	
Braidline Splicing Needle (Hook)	0273/760-2290	
Canvas - Flax RN1	0310/942-7514	
Canvas - Flax RN2	0310/942-7515	

# ANNEX C

## RIGGING EXERCISE TRAINING BOARD

To make your own cost effective training boards, which would be suitable for use in large or small classroom areas, the following equipment would be required.

### 1. THE BASE

1 Sheet of 8' X 4' Plywood (Flooring ply will suffice)

1 Sheet of 4' X 2' Plywood (allow extra 6" for join if necessary)

Both sheets may be joined using bolts through the overlap area or by making a simple fixing plate with studs to locate into holes.

Plywood for Shoes (off cuts from timber merchant)

7 Eye plates or Screw Eyes (available from hardware stores)

### 2. CORDAGE

75 metres X 8mm Polyester or other cordage available.

Strops (made from spare cordage).

Head Lashing.

### 3. BLOCKS

Makes of Blocks vary, both Barton Blocks and Holt Allen have been successfully used.

2 X Treble Blocks

10 X Double Blocks (4 with beackets)

2 X Single Blocks (with beackets)

3 X Single Blocks (without beackets)

20 X Stainless Steel Shackles

### 4. APPARATUS

#### **Heel Tackles**

3 X Double Blocks (with beackets)

3 X Double Blocks (without beackets)

18 mtrs cordage (6 metres each tackle)

#### **Purchase**

1 X Treble Block (with becket)

1 X Treble Block (without becket)

15 mtrs cordage

#### **Topping Lift**

1 X Double Block (with becket)

1 X Double Block (without becket)

20 mtrs cordage

#### **Guy Tackles**

2 X Double Blocks (with beackets)

2 X Double Blocks (without beackets)

20 mtrs cordage (10 mtrs each guy)

### 5. SPARS

Minimum of 3 required

6' - 8' (max) in length, between 2 - 3" ideal thickness (old wooden tent poles are ideal)

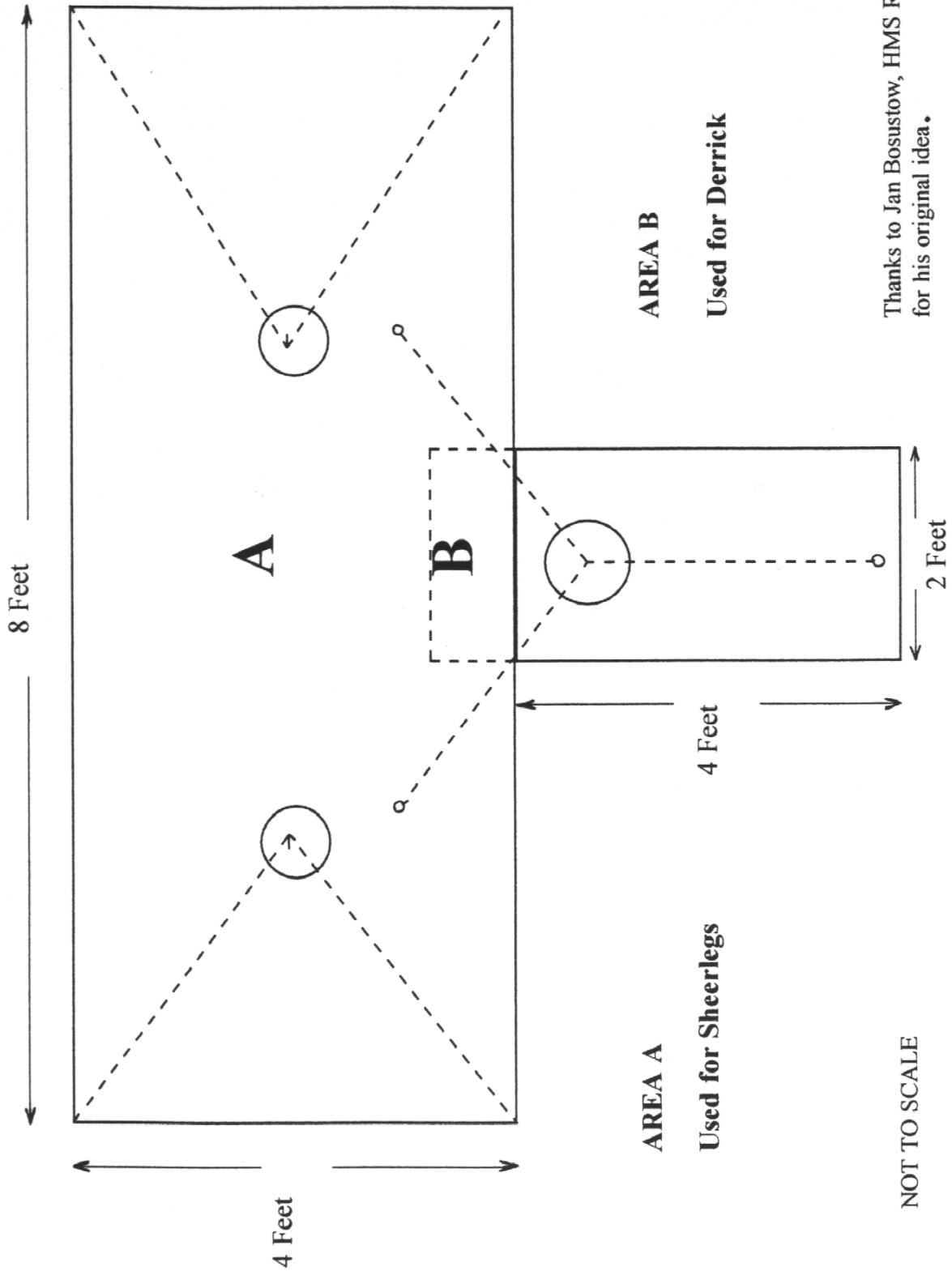

**AREA B**  
**Used for Derrick**

**AREA A**  
**Used for Sheerlegs**

Thanks to Jan Bosustow, HMS Raleigh  
 for his original idea.

NOT TO SCALE

**RIGGING EXERCISE TRAINING BOARD**

## ANNEX D

### INTERNATIONAL REGULATIONS FOR PREVENTING COLLISIONS AT SEA

#### Rule 1

##### **Application**

- (a) These Rules shall apply to all vessels upon the high seas and in all waters connected therewith navigable by seagoing vessels.
- (b) Nothing in these rules shall interfere with the operation of special rules made by an appropriate authority for roadsteads, harbours, rivers, lakes or inland waterways connected with the high seas and navigable by seagoing vessels. Such special rules shall conform as closely as possible to these rules.
- (c) Nothing in these rules shall interfere with the operations of any special rules made by the Government of any State with respect to additional station of signal lights, shapes or whistle signals for ships of war and vessels proceeding under convoy, or with respect to additional station or signal lights or shapes for fishing vessels engaged in fishing as a fleet. These additional station or signal lights, shapes or whistle signals shall, so far as possible, be such that they cannot be mistaken for any light, shape or signal authorised elsewhere under these rules.
- (d) Traffic separation schemes may be adopted by the organisation for the purpose of these rules.
- (e) Whenever the Government concerned shall have deemed that a vessel of special construction or purpose cannot comply fully with the provisions of these rules with the respect to the number, position, range or arc of visibility of lights and shapes, as well as to the disposition and characteristics of sound signalling appliances, such vessels shall comply with such other provisions in regard to the number, position, range and arc of visibility of lights and shapes, as well as the disposition and characteristics of sound signalling appliances, as her government shall have deemed to be the closest possible compliance with these rules in respect of that vessel.

#### Rule 2

##### **Responsibility**

- (a) Nothing in these rules shall exonerate any vessel, or the owner, master or crew thereof, from the consequences of any neglect to comply with these rules or of the neglect of any precaution which may be required by the ordinary practice of seamanship, or by special circumstances of the case.
- (b) In construing and complying with these rules due regard shall be had to all dangers of navigation and collision and to any special circumstances, including the limitations of the vessels involved, which may make a departure from these rules necessary to avoid immediate danger.

#### Rule 3

##### **General Definitions**

For the purpose of these rules, except where the context otherwise requires:

- (a) The word “**vessel**” includes every description of watercraft, including non-displacement craft, WIG craft and seaplanes, used or capable of being used as a means of transportation on water.
- (b) The term “**power driven vessel**” means any vessel propelled by machinery.
- (c) The term “**sailing vessels**” means any vessel under sail provided that propelling machinery, if fitted, is not being used.

- (d) The term “**vessel engaged in fishing**” means any vessel fishing with nets, lines, trawls or other fishing apparatus which restricts manoeuvrability, but does not include a vessel fishing with trolling lines or other fishing apparatus which does not restrict manoeuvrability.
- (e) The word “**seaplane**” includes any aircraft designed to manoeuvre on the water.
- (f) The term “**vessel not under command**” means a vessel which through some exceptional circumstance is unable to manoeuvre as required by these rules and is therefore unable to keep out of the way of other vessels.
- (g) The term “**vessel restricted in her ability to manoeuvre**” means a vessel which from the nature of her work is restricted in her ability to manoeuvre as required by these rules and is therefore unable to keep out of the way of other vessels. The term “**vessel restricted in their ability to manoeuvre**” shall include but not be limited to:
  - (i) a vessel engaged in laying, servicing or picking up a navigation mark, submarine cable or pipeline;
  - (ii) a vessel engaged in dredging, surveying or underwater operations;
  - (iii) a vessel engaged in replenishment or transferring persons, provisions or cargo while underway;
  - (iv) a vessel engaged in launching and recovery of aircraft;
  - (v) a vessel engaged in mine clearance operations;
  - (vi) a vessel engaged in towing operations such as severely restricts the towing vessel and her tow in their ability to deviate from their course;
- (h) The term “**vessel constrained by her draft**” means a power driven vessel which, because of her draft in relation to the available depth and width of navigable water is severely restricted in her ability to deviate from the course she is following.
- (i) The word “**underway**” means that a vessel is not at anchor or made fast to shore or ground.
- (j) The words “**length**” and “**breadth**” of a vessel means her length overall and her greatest breadth.
- (k) A vessel shall be deemed to be in sight of one other only when one can be observed visually from the other.
- (l) The term “**restricted visibility**” means any condition in which visibility is restricted by fog, mist, falling snow, heavy rain storms, sand storms or any other similar causes.
- (m) The term “**Wing-in-Ground Effect (WIG) craft**” means a multimodal craft which, in its main operation mode, flies in close proximity to the surface by utilizing surface-effect action.

## Steering and Sailing Rules

### Rule 4

#### **Application**

Rules in this section apply to any condition of visibility.

## **Rule 5**

### ***Look-out***

Every vessel shall at all times maintain a proper lookout by sight and hearing as well as by all available means appropriate in the prevailing circumstances and conditions so far as to make full appraisal of the situation and of the risk of collision.

## **Rule 6**

### ***Safe Speed***

Every vessel shall at all times proceed at safe speed so that she can take proper and effective action to avoid collision and be stopped within a distance appropriate to the prevailing circumstances and conditions. In determining a safe speed the following factors shall be among those taken into account:

- (a) By all vessels:
  - (i) The state of visibility:
  - (ii) The traffic density including concentrations of fishing vessels or any other vessels:
  - (iii) The manoeuvrability of the vessel with special reference to stopping distance and turning ability in the prevailing conditions:
  - (iv) At night in the presence of background light such as from shore lights or from back scatter of her own lights:
  - (v) The state of wind, sea and current, and the proximity of navigational hazards:
  - (vi) The draught in relation to the available depth of water:
- (b) Additionally, by vessels with operational radar:
  - (i) The characteristics, efficiency and limitations of radar equipment:
  - (ii) Any constraints imposed by the radar range scale in use:
  - (iii) The effect on radar detection of the sea state, weather and other sources of interference:
  - (iv) The possibility that small vessels, ice and other floating objects may not be detected by radar at an adequate range:
  - (v) The number, location and movement of vessels detected by radar:
  - (vi) The more exact assessment of the visibility that may be possible when radar is used to determine the range of vessels and other objects in the vicinity.

## **Rule 7**

### ***Risk of Collision***

- (a) Every vessel shall use all available means appropriate to the prevailing circumstances and conditions to determine if risk of collision exists. If there is any doubt such risks shall be deemed to exist.
- (b) Proper use shall be made of radar equipment if fitted and operational, including long range scanning to obtain early warning of risk of collision and radar plotting or equivalent systematic observation of detected objects.
- (c) Assumptions shall not be made on the basis of scanty information, especially scanty radar information.
- (d) In determining if risk of collision exists the following considerations shall be among those taken into account:
  - (i) Such risks shall be deemed to exist if the compass bearing of an approaching vessel does not appreciably change;



- (ii) Such risk may sometimes exist even when an appreciable bearing change is evident, particularly when approaching a very large vessel or a tow or when approaching a vessel at close range.

## **Rule 8**

### ***Action to Avoid Collision***

- (a) Every action to avoid collision shall, if the circumstances of the case admit, be positive, made in ample time and due regard to the observance of good seamanship.
- (b) Any alteration of course and/or speed to avoid collision shall, if the circumstances of the case admit, be large enough to be readily apparent to the other vessel observing visually or by radar; a succession of small alterations of course and/or speed should be avoided.
- (c) If there is sufficient sea room, alteration of course alone may be the most effective action to avoid a close-quarter situation provided that it is made in good time, is substantial and does not result in another close-quarters situation.
- (d) Action taken to avoid collision with another vessel shall be such as to result in passing at a safe distance. The effectiveness of the action shall be carefully checked until the other vessel is finally passed and clear.
- (e) If necessary to avoid collision or to allow more time to assess the situation, the vessel shall slacken her speed or take all way off by stopping or reversing her means of propulsion.
- (f)
  - (i) A vessel which, by any of these rules, is required not to impede the passage or safe passage of another vessel shall, when required by the circumstances of the case, take early action to allow sufficient sea room for the safe passage of the other vessel.
  - (ii) A vessel required not to impede the passage or safe passage of another vessel is not relieved of this obligation if approaching the other vessel so as to invoke risk of collision and shall, then take action, have full regard to the action which may be required by these rules of this part.
  - (iii) A vessel the passage of which is not to be impeded remains fully obliged to comply with these rules of this part when the two vessels are approaching one another so as to involve risk of collision.

## **Rule 9**

### ***Narrow Channels***

- (a) A vessel proceeding along the course of a narrow channel or fairway shall keep as near to the outer limit of the channel or fairway which lies on her starboard side as it is safe and practicable.
- (b) A vessel of less than 20 metres in length or sailing vessel shall not impede the passage of a vessel which can safely navigate only within a narrow channel or fairway.
- (c) A vessel engaged in fishing shall not impede the passage of any other vessel navigating within a narrow channel or fairway.
- (d) A vessel shall not cross a narrow channel or fairway if such crossing impedes the passage of a vessel which can safely navigate only within such channel or fairway. The latter vessel may use the sound signal prescribed in Rule 34 (d) if in doubt as to the intention of the crossing vessel.

- (e) (i) In a narrow channel or fairway when overtaking can take place only if the vessel to be overtaken has to take action to permit safe passing, the vessel intending to overtake shall indicate her intention by sounding the appropriate signal prescribed in Rule 34 (c) (i). The vessel to be overtaken shall, if in agreement sound the appropriate signal prescribed in Rule 34(c)(ii) and take steps to permit safe passing. If in doubt she may sound the signals prescribed in Rule 34 (d).
- (ii) This rule does not relieve the overtaking vessel of her obligation under Rule 13.
- (f) A vessel nearing a bend or an area of narrow channel or fairway where others may be obscured by an intervening obstruction shall navigate with particular alertness and caution and shall sound the appropriate signal prescribed in Rule 34 (e).
- (g) Any vessel shall, if the circumstances of the case admit, avoid anchoring in a narrow channel.

## **Rule 10**

### ***Traffic Separation Schemes***

- (a) This rule applies to traffic separation schemes adopted by the organisation and does not relieve any vessel of her obligation under any other rule.
- (b) A vessel using a traffic separation scheme shall;
  - (i) proceed in the appropriate traffic lane in the general direction of the traffic flow for that lane;
  - (ii) so far as practicable keep clear of a traffic separation line or separation zone;
  - (iii) normally join or leave a traffic lane at the termination of the lane, but when joining or leaving from either side shall do so at a smaller angle in the general direction of the flow as practicable.
- (c) A vessel shall as far as practicable, avoid crossing traffic lanes but if obliged to do so shall cross on the heading as nearly as practicable at right angles to the general direction of traffic flow.
- (d) (i) A vessel shall not use an inshore traffic zone when she can safely use the appropriate lane within the adjacent traffic separation scheme. However, vessels of less than 20 metres in length, sailing vessels and vessels engaged in fishing may use the inshore traffic zone.
- (ii) Notwithstanding subparagraph (d) (i), a vessel may use an inshore traffic zone when en route to or from a port, offshore installation or structure, pilot station or any other place situated within the inshore traffic zone, or to avoid immediate danger.
- (e) A vessel other than a crossing vessel or a vessel joining or leaving a lane shall not normally enter a separation zone or cross a separation line except;
  - (i) In case of emergency to avoid imminent danger.
  - (ii) To engage in fishing within a separation zone.
- (f) A vessel navigating in areas near the terminations of traffic separation schemes shall do so with particular caution.
- (g) A vessel shall so far as practicable avoid anchoring in a traffic separation scheme or in areas near its terminations.

- (h) A vessel not using a traffic separation scheme shall avoid it by as wide a margin as practicable.
- (i) A vessel engaged in fishing shall not impede the passage of any vessel following a traffic lane.
- (j) A vessel of less than 20 metres in length or a sailing vessel shall not impede the safe passage of a power driven vessel following a traffic lane.
- (k) A vessel restricted in her ability to manoeuvre when engaged in operation for the maintenance of safety of navigation in a traffic separation scheme is exempted from complying with this rule to the extent necessary to carry out the operation.
- (l) A vessel restricted in her ability to manoeuvre when engaged in an operation for the laying, servicing or picking up of a submarine cable, within a traffic separation scheme, is exempt from complying with this rule to the extent necessary to carry out the operation.

## **CONDUCT OF VESSELS IN SIGHT OF ONE ANOTHER**

### **Rule 11**

#### ***Application***

Rules in this section apply to vessels in sight of one another.

### **Rule 12**

#### ***Sailing Vessels***

- (a) When two sailing vessels are approaching one another, so as to involve risk of collision, one of them shall keep out of the way of the other as follows;
  - (i) When each has the wind on a different side, the vessel which has the wind on the port side shall keep out of the way of the other;
  - (ii) When both have the wind on the same side, the vessel which is to windward shall keep out of the way of the vessel which is to leeward;
  - (iii) If a vessel with the wind on the port side sees a vessel to windward and cannot determine with certainty whether the other vessel has the wind on the port side or the starboard side shall keep out of the way of the other vessel.
- (b) For the purpose of this rule the windward side shall be deemed to be the opposite side to that on which the mainsail is carried or, in the case of a square rigged vessel, the side opposite to that on which the largest fore and aft sail is carried.

### **Rule 13**

#### ***Overtaking***

- (a) Notwithstanding anything contained in these rules of Part B, Sections I and II any vessel overtaking any other shall keep out of the way of the vessel being overtaken.
- (b) A vessel shall be deemed to be overtaking when coming up with another vessel from a direction more than 22.5 degrees abaft her beam, that is, in such a position with reference to the vessel she is overtaking, that at night she would be able to see only the stern light of that vessel but neither of her side lights.

- (c) When a vessel is in any doubt as to whether she is overtaking another, she shall assume that this is the case and act accordingly.
- (d) Any subsequent alteration of the bearing between the two vessels shall not make the overtaking vessel a crossing vessel within the meaning of these rules or relieve her of the duty of keeping clear of the overtaking vessel until she is finally passed and clear.

#### **Rule 14**

##### ***Head-On Situation***

- (a) When motor driven vessels are meeting on reciprocal or nearly reciprocal courses so as to involve risk of collision each shall alter her course to starboard so each shall pass on the port side of each other.
- (b) Such a situation shall be deemed to exist when a vessel sees the other ahead or nearly ahead and by night she should see the masthead lights of the other in a line or nearly in a line and/or both side lights and by day she observes the corresponding aspect of the other vessel.
- (c) When a vessel is in any doubt as to whether such a situation exists she shall assume that it does exist and act accordingly.

#### **Rule 15**

##### ***Crossing Situation***

When two power driven vessels are crossing so as to invoke risk of collision, the vessel which has the other on her own starboard side shall keep out of the way and shall, if the circumstances of the case admit, avoid crossing ahead of the other vessel.

#### **Rule 16**

##### ***Action by Give-Way Vessel***

Every vessel which is directed to keep out of the way of another vessel shall, as far as possible, take early and substantial action to keep well clear.

#### **Rule 17**

##### ***Action by Stand-On Vessel***

- (a)
  - (i) Where one of two vessels is to keep out of the way the other shall keep her course and speed.
  - (ii) The latter vessel may however take action to avoid collision by her manoeuvre alone, as soon as it becomes apparent to her that the other vessel required to keep out of the way is not taking appropriate action in compliance with these rules.
- (b) When, from any cause, the vessel required to keep her course and speed finds herself so close that collision cannot be avoided by the action of the give-way vessel alone, she shall take such action as will best aid as to avoid collision.
- (c) A power driven vessel which takes action in a crossing situation in accordance with sub-paragraph (a)(ii) of this rule to avoid collision with another power driven vessel shall, if the circumstances of the case admit, not alter course to port for a
- (d) This rule does not relieve the give-way vessel of her obligation to keep out of the way.

#### **Rule 18**

##### ***Responsibilities Between Vessels***

Except where Rules 9, 10 and 13 otherwise require:

- (a) A power driven vessel under way shall keep out of the way of:
  - (i) A vessel not under command;
  - (ii) A vessel restricted in her ability to manoeuvre;
  - (iii) A vessel engaged in fishing;
  - (iv) A sailing vessel.
- (b) A sailing vessel under way shall keep out of the way of:
  - (i) A vessel not under command;
  - (ii) A vessel restricted in her ability to manoeuvre;
  - (iii) A vessel engaged in fishing.
- (c) A vessel engaged in fishing when underway shall, so far as possible, keep out of the way of:
  - (i) A vessel not under command;
  - (ii) A vessel restricted in her ability to manoeuvre.
- (d)
  - (i) Any vessel other than a vessel not under command or a vessel restricted in her ability to manoeuvre shall, if the circumstances of the case admit, avoid impeding the safe passage of a vessel constrained by her draft, exhibiting the signals in Rule 28.
  - (ii) A vessel constrained by her draft shall navigate with particular caution having full regard to her special condition.
- (e) A seaplane on the water shall, in general, keep well clear of all vessels and avoid impeding their navigation. In circumstances, however, where risk of collision exists, she shall comply with the rules of this part.
- (f)
  - (i) A WIG craft, when taking off, landing and in flight near the surface, shall keep well clear of all other vessels and avoid impeding their navigation.
  - (ii) A WIG craft operating on the water surface shall comply with the rules of this part as a power-driven vessel.

### **Conduct of Vessels in Restricted Visibility**

#### **Rule 19**

- (a) This rule applies to vessels not in sight of one another when navigating in or near an area of restricted visibility.
- (b) Every vessel shall proceed at a safe speed adapted to the prevailing circumstances and conditions of restricted visibility. A power driven vessel shall have her engines ready for immediate manoeuvre.
- (c) Every vessel shall have due regard to the prevailing circumstances and conditions of restricted visibility when complying with the rules of Section I of this part.
- (d) A vessel which detects by radar alone the presence of another vessel shall determine if a close quarter situation is developing and/or risk of collision exists. If so, she shall take avoiding action in ample time, provided that when such action consist of an alteration of course, so far as possible the following shall be avoided:
  - (i) An alteration of course to port for a vessel forward of the beam, other than for a vessel being overtaken;
  - (ii) An alteration of course towards a vessel abeam or abaft the beam.

- (e) Except where it has been determined that a risk of collision does not exist, every vessel which hears apparently forward of her beam the fog signal of another vessel, or which cannot avoid a close quarter situation with another vessel forward of her beam, shall reduce her speed to a minimum at which she can be kept on her course. She shall if necessary take all her way off and in any event navigate with extreme caution until the danger of collision is over.

## **Lights and Shapes**

### **Rule 20**

#### ***Application***

- (a) Rules in this part shall be complied with in all weathers.
- (b) The rules concerning lights shall be complied with from sunset to sunrise and during such times no other lights shall be exhibited, except such lights as cannot be mistaken for lights specified in these rules or do not impair their visibility or distinctive character, or interfere with the keeping of a proper lookout.
- (c) The lights prescribed by these rules shall, if carried, also be exhibited from sunrise to sunset in restricted visibility and may be exhibited in all other circumstances when it is deemed necessary.
- (d) The rules concerning shapes shall be complied with by day.
- (e) The lights and shapes specified in these rules shall comply with the provisions of Annex I of these regulations.

### **Rule 21**

#### ***Definitions***

- (a) ***“Mast headlight”*** means a white light placed over the fore and aft centre-line of the vessel showing an unbroken light over an arc of the horizon of 225 degrees and so fixed as to show the light from right ahead to 22.5 degrees abaft the beam on either side of the vessel.
- (b) ***“Side lights”*** means a green light on the starboard side and a red light on the port side each showing an unbroken light over an arc of the horizon of 112.5 degrees and so fixed as to show the light from right ahead to 22.5 degrees abaft the beam on its respective side. In a vessel of less than 20 metres in length the side lights may be combined in one lantern on the fore and aft centre line of the vessel.
- (c) ***“Stern light”*** means a white light placed as near as practicable at the stern showing an unbroken light over an arc of the horizon on 135 degrees and so fixed as to show the light 67.5 degrees from right aft on each side of the vessel.
- (d) ***“Towing light”*** means a yellow light having the same characteristics as the ***“stern light”*** defined in paragraph (c) of this rule.
- (e) ***“All round light”*** means a light showing an unbroken light over the arc of the horizon of 360 degrees.
- (f) ***“Flashing light”*** means a light flashing at regular intervals of a frequency of 120 flashes or more per minute.

### **Rule 22**

#### ***Visibility of Lights***

The lights prescribed in these rules shall have an intensity as specified in Section 8 of Annex I to these regulations so as to be visible at the following minimum ranges:

- (a) In vessels of 50 metres or more in length:
  - a masthead light, 6 miles;
  - a sidelight, 3 miles;
  - a sternlight, 3 miles;
  - a towing light, 3 miles;
  - a white, red, green or yellow all-round light, 3 miles.
- (b) In vessels of 12 metres or more in length but less than 50 metres length:
  - a masthead light, 5 miles: except that where the length of the vessel is less than 20 metres, 3 miles;
  - a sidelight, 2 miles;
  - a sternlight, 2 miles;
  - a towing light, 2 miles;
  - a white, red, green or yellow all-round light, 2 miles.
- (c) In vessels of less than 12 metres in length:
  - a masthead light, 2 miles;
  - a sidelight, 1 mile;
  - a sternlight, 2 miles;
  - a towing light, 2 miles;
  - a white, red, green or yellow all-round light, 2 miles.
- (d) In inconspicuous, partly submerged vessel or objects being towed:
  - a white all-round light, 3 miles.

## **Rule 23**

### ***Power-driven Vessels Underway***

- (a) A power-driven vessel underway shall exhibit:
  - (i) A masthead light forward;
  - (ii) A second masthead light abaft and higher than the forward one; except that a vessel of less than 50 metres in length shall not be obliged to exhibit such light but may do so;
  - (iii) Sidelights;
  - (iv) Sternlight.
- (b) An air-cushioned vessel when operating in the non-displacement mode shall, in addition to the lights prescribed in paragraph (a) of this rule, shall exhibit an all-round yellow flashing light.
- (c) A WIG craft only when taking off, landing and in flight near the surface shall, in addition to the lights described in paragraph (a) of this rule, exhibit a high intensity all-round flashing red light.
- (d)
  - i) A power-driven vessel of less than 12 metres in length may in lieu of the lights prescribed in paragraph (a) of this rule exhibit an all-round white light and side-lights.
  - (ii) A power-driven vessel of less than 7 metres in length whose maximum speed does not exceed 7 knots may in lieu of the lights prescribed in paragraph (a) of this rule shall exhibit an all-round white light and shall, if practicable, also exhibit sidelights.
  - (iii) The masthead light or all-round white light on a power-driven vessel of less than 12 metres in length may be displaced from the fore and aft centre line of the vessel if the centre line fitting is non practicable, providing that the sidelights are combined in one lantern which shall

be carried on the fore and aft centre line of the vessel or located as nearly as practicable in the same fore and aft line as the masthead light of the all-round white light.

## **Rule 24**

### ***Towing and Pushing***

- (a) A power-driven vessel when towing shall exhibit:
  - (i) Instead of the light prescribed in Rule 23 (a)(i) or (a)(ii), two masthead lights in a vertical line. When the length of the tow, measuring from the stern of the towing vessel to the after end of the tow exceeds 200 metres, three such lights in a vertical line:
  - (ii) Sidelights;
  - (iii) A sternlight;
  - (iv) A towing light in a vertical line above the stern light;
  - (v) When the length of the tow exceeds 200 metres a diamond shape where it can best be seen.
- (b) When a pushing vessel and a vessel being pushed ahead are rigidly connected in a composite unit they shall be regarded as a power-driven vessel and exhibit the lights prescribed in the Rule 23.
- (c) A power-driven vessel when pushing ahead or towing alongside, except in the case of a composite unit shall exhibit:
  - (i) Instead of the light prescribed in Rule 23 (a)(i) or (a)(ii), two masthead lights in a vertical line:
  - (ii) Sidelights;
  - (iii) Stern light.
- (d) A power-driven vessel to which paragraphs (a) or (c) of this rule apply shall also comply with Rule 23 (a)(ii).
- (e) A vessel or object being towed, other than those mentioned in paragraph (g) of this rule, shall exhibit:
  - (i) Sidelights;
  - (ii) Sternlight;
  - (iii) When the length of the tow exceeds 200 metres, a diamond shape where it can best be seen.
- (f) Providing that any number of vessels being towed alongside or pushed in a group shall be lighted as one vessel,
  - (i) A vessel being pushed ahead not being part of a composite unit, shall exhibit at the forward end, sidelights;
  - (ii) A vessel being towed alongside shall exhibit a stern light and at the forward end, sidelights.
- (g) An inconspicuous, partly submerged vessel or object, or combination of such vessels or objects being towed, shall exhibit:
  - (i) If it is less than 25 metres in breadth, one all-round white light at or near the forward end and one at or near the after end except that dracones need not exhibit a light at or near the forward end.
  - (ii) If it is 25 metres or more in breadth two additional all-round white lights at or near the extremities of its breadth;
  - (iii) If it exceeds 1,000 metres in length additional all-round white lights between the lights prescribed in sub-paragraphs (i) and (ii) so that the distance between the lights shall not exceed 100 metres;
  - (iv) A diamond shape at or near the aftermost extremity of the last vessel or object being towed and if the length exceeds 200 metres an



additional diamond shape where it can best be seen and located as far forward as it is practicable.

- (h) Where from any sufficient cause it is impracticable for a vessel or object being towed to exhibit the lights or shapes prescribed in paragraph (e) or (g) of this rule, all possible measures shall be taken to light the vessel or object being towed or at least to indicate the presence of such a vessel or object.
- (i) Where from any sufficient cause it is impracticable for a vessel not normally engaged in towing operations to display the lights prescribed in paragraph (a) or (c) of this rule, such vessel shall not be required to exhibit these lights when engaged in towing another vessel in distress or otherwise in need of assistance. All possible measures shall be taken to indicate the nature of the relationship between the towing vessel and the vessel being towed as authorised by Rule 36 in particular by illuminating the towline.

## **Rule 25**

### ***Sailing Vessels Under Way and Vessels Under Oars***

- (a) A vessel under way shall exhibit:
  - (i) Sidelights;
  - (ii) Sternlight.
- (b) In a sailing vessel of less than 20 metres in length the lights prescribed in paragraph (a) of this rule may be combined in one lantern carried at or near the top of the mast where it can best be seen.
- (c) A sailing vessel under way may, in addition to the lights prescribed in paragraph (a) of this rule, exhibit at or near the top of the mast, where they can best be seen, two all-round lights in a vertical line, the upper being red and the lower being green, but these lights shall not be exhibited in conjunction with a combined lantern permitted by paragraph (b) of this rule.
- (d)
  - (i) A sailing vessel of less than 7 metres in length shall, if practicable exhibit the lights prescribed in paragraph (a) or (b) of this rule, but if she does not, she shall have ready at hand an electric torch or lighted lantern showing a white light which shall be exhibited in sufficient time to prevent a collision.
  - (ii) A vessel under oars may exhibit the lights prescribed in this rule for sailing vessels, but if she does not, she shall have ready at hand an electric torch or lighted lantern showing a white light which shall be exhibited in sufficient time to prevent collision.
- (e) A vessel proceeding under sail when also being propelled by machinery shall exhibit forward where it can best be seen a conical shape, apex downwards.

## **Rule 26**

### ***Fishing Vessels***

- (a) A vessel engaged in fishing, whether under way or at anchor, shall exhibit only the lights and shapes prescribed in this rule.
- (b) A vessel when engaged in trawling, by which is meant by the dragging through the water of a dredge net or other apparatus used as a fishing appliance, shall exhibit:

- (i) Two all-round lights in a vertical line, the upper being green and the lower white, or a shape consisting of two cones with their apexes together in a vertical line one above the other;
- (ii) A mast head light abaft of and higher than the all-round green light; a vessel of less than 50 metres in length shall not be obliged to exhibit such a light but may do so;
- (iii) When making way through the water, in addition to the lights prescribed in this paragraph, side lights and a sternlight.
- (c) A vessel engaged in fishing, other than trawling shall exhibit:
  - (i) Two all-round lights in a vertical line, the upper being red and the lower white or a shape consisting of two cones with apexes together in a vertical line one above the other;
  - (ii) Where there is outlying gear extending more than 150 metres horizontally from the vessel, an all-round white light or a cone apex upwards in the direction of the gear;
  - (iii) When making way through the water, in addition to these lights prescribed in this paragraph, sidelights and a stern light.
- (d) The additional signals described in Annex II to these regulations apply to a vessel engaged in fishing in close proximity to other vessels engaged in fishing.
- (e) A vessel when not engaged in fishing shall not exhibit the lights or shapes prescribed in this rule, but only those prescribed for vessel of her length.

## **Rule 27**

### ***Vessels Not Under Command or Restricted in their Ability to Manoeuvre***

- (a) A vessel not under command shall exhibit:
  - (i) Two all-round red lights in a vertical line where they can best be seen;
  - (ii) Two balls or similar shapes in a vertical line where they can best be seen;
  - (iii) When making way through the water, in addition to the lights prescribed in this paragraph, sidelights and sternlight.
- (b) A vessel restricted in her ability to manoeuvre, except the vessel engaged in mine clearance operations, shall exhibit:
  - (i) Three all-round lights in a vertical line where they can best be seen. The highest and lowest of these lights shall be red and the middle light shall be white;
  - (ii) Three shapes in a vertical line where they can best be seen. The highest and lowest of these shapes shall be balls and the middle one a diamond;
  - (iii) When making way through the water, a masthead light or lights, sidelights and a starlight, in addition to the lights prescribed in sub-paragraph (i);
  - (iv) When at anchor, in addition to the lights or shapes prescribed in sub-paragraphs (i) and (ii) the light, lights or shape prescribed in Rule 30.
- (c) A power-driven vessel engaged in a towing operation such as severely restricts the towing vessel and her tow in their ability to deviate from their course shall, in addition to the lights and shapes prescribed in Rule 24(a), exhibit the lights and shapes prescribed in sub-paragraphs (b) (i) and (ii) of this rule.

- (d) A vessel engaged in dredging or underwater operations when restricted in her ability to manoeuvre, shall exhibit the lights and shapes prescribed in sub-paragraphs (b) (i) (ii) and (iii) of this rule and shall in addition, when an obstruction exists, exhibit:
  - (i) Two all-round red lights or two balls in a vertical line to indicate the side on which the obstruction exists;
  - (ii) Two all-round green lights or two diamonds in a vertical line to indicate the side on which the other vessel may pass;
  - (iii) When an anchor, the lights and shapes prescribed in this paragraph instead of the lights or shapes prescribed in Rule 30.
- (e) Whenever the size of the vessel engaged in diving operations make it impracticable to exhibit all lights and shapes prescribed in paragraph (d) of this rule, the following shall be exhibited:
  - (i) Three all-round lights in a vertical line where they can best be seen the highest and lowest of these lights shall be red and the middle lights shall be white;
  - (ii) A rigid replica of the International Code flag "A" not less than one metre in height. Measures shall be taken to ensure its all-round visibility.
- (f) A vessel engaged in mine clearance operations shall in addition to the lights prescribed for a power driven vessel in Rule 23 or to the lights and shapes for a vessel at anchor in Rule 30 as appropriate, exhibit three all-round green lights or three balls. One of these lights or shapes shall be exhibited near the fore mast head and one at each end of the fore yard. These lights and shapes indicate that it is dangerous for another vessel to approach within 1,000 metres of the mine clearance vessel.
- (g) Vessel of less than 12 metres in length, except those engaged in diving operations, shall not be required exhibit the lights and shapes prescribed in this rule.
- (h) The signals prescribed in this rule are not signals of vessel in distress and requiring assistance. Such signals are contained in Annex IV to these regulations.

## **Rule 28**

### ***Vessels Constrained by their Draft***

A vessel constrained by her draft may, in addition to the lights prescribed for power driven vessels in Rule 23 exhibit where they can best be seen three all-round red lights in a vertical line or a cylinder.

## **Rule 29**

### ***Pilot Vessels***

- (a) A vessel engaged on pilotage duty shall exhibit:
  - (i) At or near the masthead two all-round lights in a vertical line, the upper being white and the lower red;
  - (ii) When under way, in addition, sidelights and sternlight;
  - (iii) When at anchor, in addition to the lights prescribed in sub-paragraph (i) the light, lights or shapes prescribed in Rule 30 for a vessel at anchor.
- (b) A pilot vessel when not engaged on pilotage duty shall exhibit the lights and shapes prescribed for a vessel of her length.

### **Rule 30**

#### ***Anchored Vessels and Vessels Aground***

- (a) A vessel at anchor shall exhibit where it can best be seen:
  - (i) In the fore part, an all-round white light or one ball;
  - (ii) At or near the stern and at a lower level than the light prescribed in sub-paragraph (i), and all-round white light.
- (b) A vessel of less than 50 metres in length may exhibit an all-round white light where it can best be seen instead of the lights prescribed in paragraph (a) of this rule.
- (c) A vessel at anchor may, and a vessel of 100 metres and more in length, shall also use the available working or equivalent lights to illuminate her decks.
- (d) A vessel aground shall exhibit the lights prescribed in paragraph (a) or (b) of this rule and in addition, where it can best be seen;
  - (i) Two all-round red lights in a vertical line;
  - (ii) Three balls in a vertical line.
- (e) A vessel of less than 7 metres in length, when at anchor, not in or near a narrow channel, fairway or anchorage, or where other vessels normally navigate, shall not be required to exhibit the lights or shape prescribed in paragraphs (a) or (b) of this rule.
- (f) A vessel of less than 12 metres in length, when aground, shall not be required to exhibit the lights or shapes prescribed in sub-paragraph (d) (i) and (ii) of this rule.

### **Rule 31**

#### ***Seaplanes and WIG Craft***

Where it is impracticable for a seaplane or a WIG craft to exhibit lights and shapes of the characteristics or in the positions prescribed in the rules of this part she shall exhibit lights and shapes as closely similar in characteristics and position as it is possible.

## **SOUND AND LIGHT SIGNALS**

### **Rule 32**

#### ***Definitions***

- (a) The word “***whistle***” means any sound signalling appliance capable of producing the prescribed blasts and which complied with the specification in Annex III of these regulations.
- (b) The term “***short blast***” means a blast of about one second’s duration.
- (c) The term “***prolonged blast***” means a blast of from four to six seconds’ duration.

### **Rule 33**

#### ***Equipment for Sound Signals***

- (a) A vessel of twelve metres or more in length shall be provided with a whistle, a vessel of 20 metres or more in length shall be provided with a bell in addition to the whistle, a vessel of 100 metres in length shall, in addition, be provided with a gong, the tone and sound of which cannot be confused with that of the bell. The whistle, bell and gong shall comply with the specification of Annex III of these regulations. The bell and gong or

both may be replaced by other equipment having the same respective sound characteristics, provided that manual sounding of the required signals shall always be possible.

- (b) A vessel of less than 12 metres in length shall not be obliged to carry the sound signalling appliances prescribed in paragraph (a) of this rule but if she does not, she shall be provided with some other means of making an effective sound signal.

## Rule 34

### ***Manoeuvring and Warning Signals***

- (a) When vessels are in sight of one another, a power-driven vessel under way, when manoeuvring as authorized or required by these rules, shall indicate that manoeuvre by the following signals on her whistle:
- one short blast to mean ***“I am altering my course to starboard”***;
  - two short blasts to mean ***“I am altering my course to port”***;
  - three short blasts to mean ***“I am operating astern propulsion”***.
- (b) Any vessel may supplement the whistle signals prescribed in paragraph (a) of this rule by light signals, repeated as appropriate, whilst the manoeuvre is being carried out:
- (i) These light signals shall have the following significance:
- one flash to mean ***“I am altering my course to starboard”***;
  - two flashes to mean ***“I am altering my course to port”***;
  - three flashes to mean ***“I am operating astern propulsion”***;
- (ii) The duration of each flash shall be about one second, the interval between flashes shall be about one second, and the interval between successive signals shall be not less than ten seconds;
- (iii) The lights used for this signal shall, if fitted, be an all-round white light visible at a minimum range of five miles and shall comply with the provisions of Annex I to these regulations.
- (c) When in sight of one another in a narrow channel or fairway:
- (i) A vessel intending to overtake another shall in compliance with Rule 9 (e) (i) indicate her intention by the following signals on her whistle:
- Two prolonged blasts followed by one short blast to mean ***“I intend to overtake you on your starboard side”***;
  - Two prolonged blasts followed by two short blasts to mean ***“I intend to overtake you on your port side”***;
- (ii) The vessel about to be overtaken when acting in accordance with Rule 9 (e) (i) shall indicate her agreement by the following signal on her whistle:
- one prolonged, one short, one prolonged and one short blast, in that order;
- (d) When vessels in sight of one another are approaching each other and from any cause either vessel fails to understand the intentions or action of the other, or it is in doubt whether sufficient action is being taken by the other to avoid collision, the vessel in doubt shall immediately indicate such doubt by giving at least five short and rapid blasts on the whistle. Such signal may be supplemented by a light signal of at least five short and rapid flashes.
- (e) A vessel nearing a bend or an area of channel or fairway where other vessels may be obscured by an intervening obstruction shall sound one prolonged blast. Such signal shall be answered with one prolonged blast

- by any approaching vessel that may be within hearing sound around the bend or behind the intervening obstruction.
- (f) If whistles are fitted on a vessel at a distance apart of more than one hundred metres, one whistle only shall be used for giving manoeuvring and warning signals.

### **Rule 35**

#### ***Sound Signals in Restricted Visibility***

In or near an area of restricted visibility, whether by day or night, the signals prescribed in this rule shall be used as follows:

- (a) A power driven vessel making way through the water shall sound at intervals of not more than two minutes one prolonged blast.
- (b) A power-driven vessel under way but stopped and making no way through the water shall sound at intervals of not more than two minutes two prolonged blasts in succession and an interval of about two second between them.
- (c) A vessel not under command, a vessel restricted in her ability to manoeuvre, a vessel constrained by her draft, a sailing vessel, a vessel engaged in fishing and a vessel engaged in towing or pushing another vessel shall instead of the signals prescribed in paragraphs (a) or (b) of this rule, sound at intervals of not more than two minutes three blasts in succession namely one prolonged followed by two short blasts.
- (d) A vessel engaged in fishing, when at anchor, and a vessel restricted in her ability to manoeuvre when carrying out her work at anchor, shall instead of the signals prescribed in paragraph (g) of this rule sound the signals prescribed in paragraph (c) of this rule.
- (e) A vessel towed or if more than one vessel is towed the last vessel of the tow, if manned, shall at intervals not more than two minutes sound four blasts in succession, namely one prolonged followed by three short blasts. When practicable, this signal shall be made immediately after the signal made by the towing vessel.
- (f) When a pushing vessel and a vessel being pushed ahead are rigidly connected in a composite unit they shall be regarded as a power driven vessel and shall give the signals prescribed in paragraphs (a) or (b) or this rule.
- (g) A vessel at anchor shall at intervals of not more than one minute ring a bell rapidly for about five seconds. In a vessel of 100 metres or more in length the bell shall be sounded in the forepart of the vessel. Immediately after the ringing of the bell the gong shall be sounded rapidly for about five seconds in the afterpart of the vessel. A vessel at anchor may in addition sound three blasts in succession, namely one short blast, one prolonged and one short blast, to give warning of her position and of the possibility of collision to an approaching vessel.
- (h) A vessel aground shall give the bell signal and if required the gong signal prescribed in paragraph (g) of this rule and shall, in addition, give three separate and distinct strokes of the bell immediately before and after the rapid ringing of the bell. A vessel aground may in addition sound the appropriate whistle signal.
- (i) A vessel of twelve metres or more but less than 20 metres in length shall not be obliged to give the bell signals prescribed in paragraphs (g) and (h)

or this rule. However, if she does not, she shall make some other efficient sound signal at intervals of not more than two minutes.

- (j) A vessel of less than 12 metres in length shall not be obliged to give the above mentioned signals but, if she does not, shall make some other efficient sound signal at intervals of not more than two minutes.
- (k) A pilot vessel when engaged in pilotage duty may in addition to the signals prescribed in paragraphs (a), (b) or (g) of this rule sound an identity signal consisting of four short blasts.

## **Rule 36**

### ***Signals to Attract Attention***

If necessary to attract the attention of another vessel any vessel may make light or sound signals that cannot be mistaken for any signal authorized elsewhere in these rules, or may direct the beam of her searchlight in the direction of the danger, in such a way as not to embarrass any vessel. Any light to attract the attention of another vessel shall be such that it cannot be mistaken for any aid to navigation. For the purpose of this rule the use of high-intensity intermittent or revolving lights, such as strobe lights, shall be avoided.

## **Rule 37**

### ***Distress Signals***

1. When a vessel is in distress and requires assistance she shall use or exhibit the signals described below.
  - (a) A gun or other explosive signal fired at intervals of about one minute;
  - (b) A continuous sounding with any fog signalling apparatus;
  - (c) Rockets or shells, throwing red stars fired one at a time at short intervals;
  - (d) A signal made by radiotelegraph or by any other signally method consisting of the group ...---... (SOS) in the morse code;
  - (e) A signal sent by radiotelephony consisting of the spoken work **mayday**;
  - (f) The International code signal of distress indicated by NC;
  - (g) A signal consisting of a square flag having above or below it a ball or anything resembling a ball;
  - (h) Flames on the vessel (as from a burning tar barrel, oil barrel, etc.);
  - (i) A rocket parachute flare or a hand flare showing a red light;
  - (j) A smoke signal giving off orange coloured smoke;
  - (k) Slowly and repeatedly raising and lowering arms outstretched to each side;
  - (l) The radiotelegraph alarm signal;
  - (m) The radiotelephone alarm signal;
  - (n) Signals transmitted by emergency positioning-indicating radio beacons;
  - (o) Approved signals transmitted by radio communication systems including survival craft radar transponders.
2. The use or exhibition of any of the foregoing signals except for the purpose of indicating distress and need of assistance and the use of other signals which may be confused with any of the above signals is prohibited.
3. Attention is drawn to the relevant sections of the International Code of Signals, the Merchant Ship Search and Rescue Manual and the following signals:
  - (a) A piece of orange coloured canvas with either a black square and circle or other appropriate symbol (for identification from the air);
  - (b) A dye marker.

## EXEMPTIONS

### Rule 38

#### *Exemptions*

Any vessel (or class of vessels) provided that she complies with the requirements of the International Regulations for Preventing Collisions at Sea, 1960, the keel of which is laid or which is at the corresponding stage of construction before the entry into force of these regulations may be exempt from compliance therewith as follows:

- (a) The installation of lights with ranges prescribed in Rule 22, until four years after the date of entry into force of these regulations.
- (b) The installation of lights with colour specifications as prescribed in Section 7 of Annex I to these regulations, until four years after the date of entry into force of these regulations.
- (c) The repositioning of lights as a result of conversion from Imperial to Metric units and rounding up measurement figures, permanent exemption.
- (d)
  - (i) The repositioning of mast headlights on vessels of less than 150 metres in length, resulting from the prescriptions of Section 3 (a) of Annex I to these regulations, permanent exemption.
  - (ii) The repositioning of masthead lights on vessel of 150 metres or more in length, resulting from the prescriptions of Section 3(a) of Annex I to these regulations, until nine years after the date of entry into force of these regulations.
- (e) The repositioning of mast headlights resulting from the prescriptions of 2(b) of Annex I to these regulations, until nine years after the date of entry into force of these regulations.
- (f) The repositioning of side lights resulting from the prescriptions of Sections 2(g) and 3(b) of Annex I to these regulations, until nine years after the date of entry into force of these regulations.
- (g) The requirements of sound signal appliances prescribed in Annex III of these regulations, until nine years after the date of entry into force of these regulations.
- (h) The repositioning of all-round lights resulting from the prescription of Section 9(b) of Annex I to these regulations, permanent exemption.